

**AD12-16(PCI)E
AD12-16U(PCI)E
AD16-16(PCI)E**

Analog Input Board for PCI

User's Guide

 **CONTEC**

Copyright

Copyright 1997 CONTEC Co., LTD. ALL RIGHTS RESERVED

No part of this document may be copied or reproduced in any form by any means without prior written consent of CONTEC Co., LTD.

CONTEC MICROELECTRONICS makes no commitment to update or keep current the information contained in this document. The information in this document is subject to change without notice.

All relevant issues have been considered in the preparation of this document. Should you notice an omission or any questionable item in this document, please feel free to notify CONTEC Co., LTD.

Regardless of the foregoing statement, CONTEC assumes no responsibility for any errors that may appear in this document nor for results obtained by the user as a result of using this product.

Trademarks

MS, Microsoft, MS-DOS and Windows are trademarks of Microsoft Corporation. Other brand and product names are trademarks of their respective holder.

Product Configuration

- AD12-16(PCI)E, AD12-16U(PCI)E or AD16-16(PCI)E Board...1
- AD12-16(PCI)E, AD12-16U(PCI)E and AD16-16(PCI)E boards User's Manual (this booklet)...1
- Setup Disk (3½ inch 2HD)...1

Unpacking

The board is specially packed in an anti-static plastic bag to prevent damage during shipment.

Check the contents to make sure that you have everything listed above. If you do not have all the items, contact CONTEC.

Notes!

- *Do not remove the board from its protective packaging until the computer is open and you are ready to install. Static can be very damaging to all electronic components.*
- *Optional software driver and connection products are available from CONTEC. Call for more information.*

Table of Contents

Copyright.....	i
Trademarks	i
Product Configuration	ii
1. Introduction	1
About the Boards	1
Features.....	1
Limited Three Year Warranty	3
How to Obtain Service.....	3
Liability	3
About this Manual.....	4
2. Component Locations and Settings	5
Component Locations and Default Settings.....	5
Analog Input Settings.....	10
Analog Output Setting	13
Set Counter and Digital I/O	14
3. Board Setup	15
Use CONTEC Windows Software Products.....	15
When Not Using CONTEC Software for Windows	16
For Windows 98 Systems.....	16
For Windows 95 Systems.....	19
For other OS systems	24
4. External Connections	25
External Connections	25
Signal Connection.....	28
Analog Output Connection.....	31
Digital I/O Connection.....	32

5. Operation Functions	33
Analog Input Function (A/D).....	33
Analog Output Function (D/A).....	45
Digital Input Function [DI].....	46
Digital Output Function [DO].....	46
Counter Function.....	46
Interrupt Function.....	48
6. Demonstration Program	49
7. Calibration Program	53
8. System Reference.....	57
Specifications	57
Timing of External Control Signals.....	62
9. Troubleshooting	63
10. Index	65

List of Figures

Figure 2.1.	AD12-16(PCI)E Component Locations and Default Settings.....	6
Figure 2.2.	AD12-16U(PCI)E Component Locations and Default Settings.....	7
Figure 2.3.	AD16-16(PCI)E Component Locations and Default Settings.....	8
Figure 2.4.	Board ID Setting (SW1)	9
Figure 2.5.	Setting the Interrupt Use.....	9
Figure 2.6.	Setting Input Mode	10
Figure 2.7.	AD12-16(PCI)E's Input Range Settings	11
Figure 2.8.	AD12-16U(PCI)E's Input Range Settings	11
Figure 2.9.	AD16-16(PCI)E's Input Range Settings	12
Figure 2.10.	AD12-16(PCI)E's Output Range Settings.....	13
Figure 2.11.	AD12-16U(PCI)E's Output Range Settings.....	13
Figure 2.12.	AD16-16(PCI)E's Output Range Settings.....	13
Figure 2.13.	Jump the CN2 Pin10 as DO3 or CNT Output	14
Figure 2.14.	Select Gate Signal of Counter 1 and 2	14
Figure 2.15.	Select Clock Signal of Counter.....	14
Figure 4.1.	CN1 Signal Configuration.....	25
Figure 4.2.	CN2 Signal Configuration.....	26
Figure 4.3.	Single-ended Input Connection (Flat Cable).....	28
Figure 4.4.	Single-ended Input Connection (Shield Cable).....	28
Figure 4.5.	Differential Input Connection (Flat Cable)	29
Figure 4.6.	Differential Input Connection (Shield Cable)	29
Figure 4.7.	Analog Output Connection (Flat Cable)	31

Figure 4.8.	Analog Output Connection (Shield Cable).....	31
Figure 4.9.	Digital Input Connection	32
Figure 4.10.	Digital Output Connection.....	32
Figure 5.1.	Single Channel Mode Operation.....	34
Figure 5.2.	Multichannel Mode Operation.....	34
Figure 5.3.	Example of Sampling Clock Error of Single Channel	35
Figure 5.4.	Example of Sampling Clock Error of Multichannels	35
Figure 5.5.	Converted Data Comparison Conditions for Starting Sampling	36
Figure 5.6.	Converted Data Comparison Conditions for Stopping Sampling	38
Figure 5.7.	Controlling Number of Samplings.....	39
Figure 5.8.	Number of Repeats.....	40
Figure 5.9.	FIFO Format Buffer Memory	41
Figure 5.10.	Ring Format Buffer Memory	43
Figure 5.11.	Timing Diagram for the Analog Output Operation .	45
Figure 5.12.	Digital Input	46
Figure 5.13.	Digital Output	46
Figure 5.14.	Counter Configuration.....	47
Figure 7.1.	Instruments for Calibration.....	53
Figure 8.1.	Block Diagram.....	61
Figure 8.2.	Timing Chart of External Sampling Clock.....	62
Figure 8.3.	Timing Chart of External Sampling Start Trigger ...	62
Figure 8.4.	Timing Chart of External Sampling Stop Trigger ...	62

List of Tables

Table 5.1.	Input Range and Coefficient.....	43
Table 5.2.	Examples of Converted Data (+/-10V range/Input gain = 1).....	44
Table 5.3.	Examples of Output Voltages and Their Digital Data (12-bit)	45
Table 5.4.	Example of Jumper Settings for Counter.....	47
Table 5.5.	Interrupt Request Signal Events	48
Table 6.1.	Contents of the Diskette	49
Table 7.1.	AD12-16(PCI)E's Potentiometers for Analog Input Circuit.....	54
Table 7.2.	AD12-16U(PCI)E's Potentiometers for Analog Input Circuit.....	54
Table 7.3.	AD16-16(PCI)E's Potentiometers for Analog Input Circuit.....	54
Table 7.4.	Potentiometers for Analog Output Circuits of AD12-16(PCI)E	55
Table 7.5.	Potentiometers for Analog Output Circuits of AD12-16U(PCI)E.....	55
Table 7.6.	Potentiometers for Analog Output Circuits of AD16-16(PCI)E	55
Table 8.1.	AD12-16(PCI)E.....	57
Table 8.2.	AD12-16U(PCI)E	58
Table 8.3.	AD16-16(PCI)E.....	59
Table 8.4.	Common to All of the three boards	60
Table 8.5.	Timing Table of External Control Signals	62

1. Introduction

About the Boards

The AD12-16(PCI)E, AD12-16U(PCI)E and AD16-16(PCI)E boards are multifunction IBM PC add-on interface boards. The boards convert analog signals to digital data (A/D) and convert digital data to analog signals (D/A). In addition, they supply four digital input channels and four digital output channels. These boards feature a 256K-word on board memory to maximize the A/D conversion speed. The boards also support interrupt operations.

The AD12-16(PCI)E and AD12-16U(PCI)E are a 12-bit A/D and D/A conversion resolution.

The AD16-16(PCI)E is a 16-bit A/D and D/A conversion resolution.

Features

- Up to 1 μ sec A/D speed (1MHz) of AD12-16U(PCI)E
Up to 10 μ sec A/D speed (100KHz) of AD12-16(PCI)E and AD16-16(PCI)E
- 16-bit resolution of AD16-16(PCI)E
12-bit resolution of AD12-16(PCI)E and AD12-16U(PCI)E
- 16 single-ended analog inputs or 8 differential analog inputs (Up to 32 single-ended or 16 differential inputs can be expandable through an optional terminal unit).
- 256K-word on board memory to maximize A/D sampling speeds and enable background processing.
This buffer memory can be used either by FIFO method or by ring method.
- Various A/D sampling control functions.
Start or stop a sampling (A/D) not only by software but also by value of the analog signal or by detecting a TTL level external signal. The sampling clock that determines the sampling speed can be selected from the on board clock or from an external clock signal.
- 1-channel analog output
- Four TTL level digital input and four TTL level digital output channels.

- One i8254 compatible counter
- Various interrupt events such as end of sampling, change in external signal, error detected, and so on.
- A lot of optional products
 - ATSS-16: simultaneous sampling/hold terminal unit.
 - ATII-8: electrically isolated conditioning terminal unit with CJC circuit and current input function.
 - ATLF-8: differential input conditioning terminal unit with lowpass filter function.
 - ATCH-16(PCI) and ATUH-16(PCI): input channel expanding terminal units.
 - DTP-3(PC) and FTP-15: easy connecting screw terminal units.
 - ATP-16: BNC connector terminal unit for single-ended inputs.
 - PCC16PS: coaxial cable for single-ended input.
 - PCD8PS: two-wire shield cable for differential input.

Note!

To operate the AD12-16(PCI)E, AD12-16U(PCI)E and AD16-16(PCI)E boards, an optional software driver is needed. Call your dealer for more information about this software driver.

For further information, see page 57 of "System Reference".

Limited Three Year Warranty

CONTEC interface boards are warranted by CONTEC Co., LTD. to be free from defects in material and workmanship for up to three years from the date of purchase by the original purchaser.

Repair will be free of charge only when this device is returned freight prepaid with a copy of the original invoice and a Return Merchandise Authorization to the distributor or the CONTEC group office, from which it was purchased.

This warranty is not applicable for scratches or normal wear, but only for the electronic circuitry and original board. It is also not applicable if the device has been tampered with or damaged through abuse, mistreatment, neglect or unreasonable use, or if the original invoice is not included, in which case repairs will be considered beyond the warranty policy. If a replacement with a new device is needed, regular factory prices will be charged, and the product will be returned to you COD, and no other written warranty will apply.

The obligation of the warrantor is solely to repair or replace the product. In no event will the warrantor be liable for any incidental or consequential damages due to such defect or consequences that arise from inexperienced usage, misuse, or malfunction of this device.

How to Obtain Service

For replacement or repair, return the device freight prepaid, with a copy of the original invoice. Please obtain a Return Merchandise Authorization Number (RMA) from the CONTEC group office where you purchased before returning any product.

*** No product will be accepted by CONTEC group without the RMA number.**

Liability

The obligation of the warrantor is solely to repair or replace the product. In no event will the warrantor be liable for any incidental or consequential damages due to such defect or consequences that arise from inexperienced usage, misuse, or malfunction of this device.

About this Manual

This manual provides instructions for setting up and using the AD12-16(PCI)E, AD12-16U(PCI)E and AD16-16(PCI)E boards. It is divided into seven main sections: Setup, External Connection, Operation Functions, Demonstration Programs, Calibration, System Reference, and Troubleshooting.

- Chapter 1 Introduction
- Chapter 2 Component Locations and Settings
contains all the information necessary to setup the AD12-16(PCI)E, AD12-16U(PCI)E and AD16-16(PCI)E boards.
- Chapter 3 Board Setup
Explains how to set up the board
- Chapter 4 External connection
details the signal assignment of the external connectors and gives some connecting examples.
- Chapter 5 Operation Functions
explains the basic operation function of this board.
- Chapter 6 Demonstration Programs
explains the basic use of demonstration programs for MS-DOS.
- Chapter 7 Calibration
contains the method of calibration and equipments.
- Chapter 8 System Reference
contains the specifications for each of AD12-16(PCI)E, AD12-16U(PCI)E and AD16-16(PCI)E boards.
- Chapter 9 Troubleshooting
is a series of questions to ask yourself and steps to take to solve problems on your own. It also includes a checklist to fill out before calling CONTEC for help.

All addresses and examples are written in Hexadecimal.

2. Component Locations and Settings

This section covers everything from getting an AD12-16(PCI)E, AD12-16U(PCI)E or AD16-16(PCI)E boards out of the box to plugging it into your computer.

The following installation procedure is for the AD12-16(PCI)E, AD12-16U(PCI)E and AD16-16(PCI)E boards only and does not include instructions for any accessories.

Component Locations and Default Settings

The AD12-16(PCI)E, AD12-16U(PCI)E and AD16-16(PCI)E boards are shipped from the factory with the following settings:

1. AD12-16(PCIE):

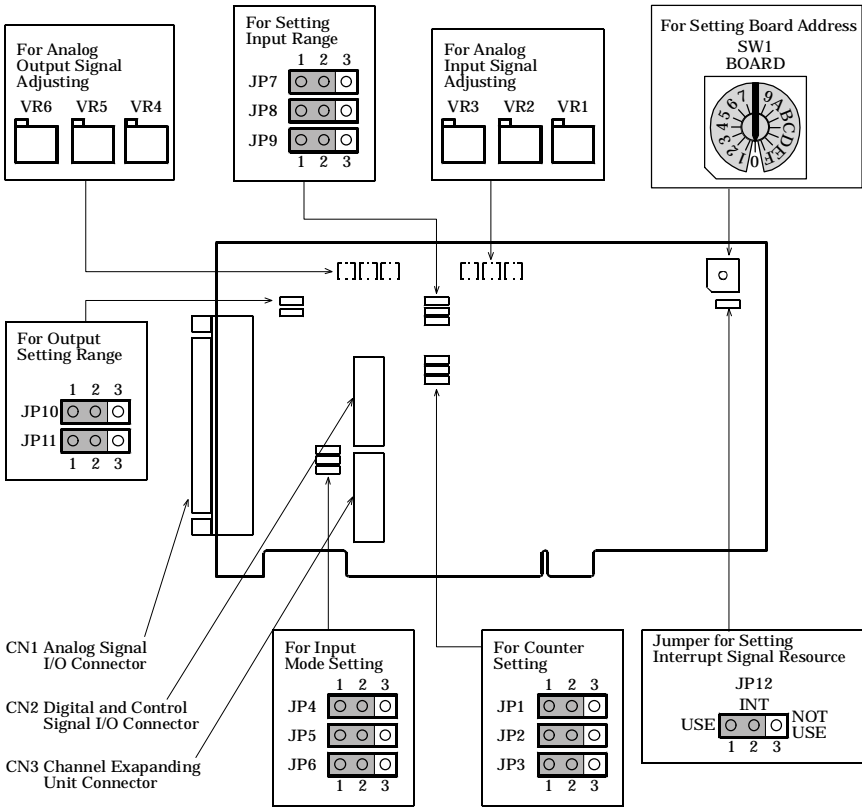

Figure 2.1. AD12-16(PCIE) Component Locations and Default Settings

2. AD12-16U(PCI)E:

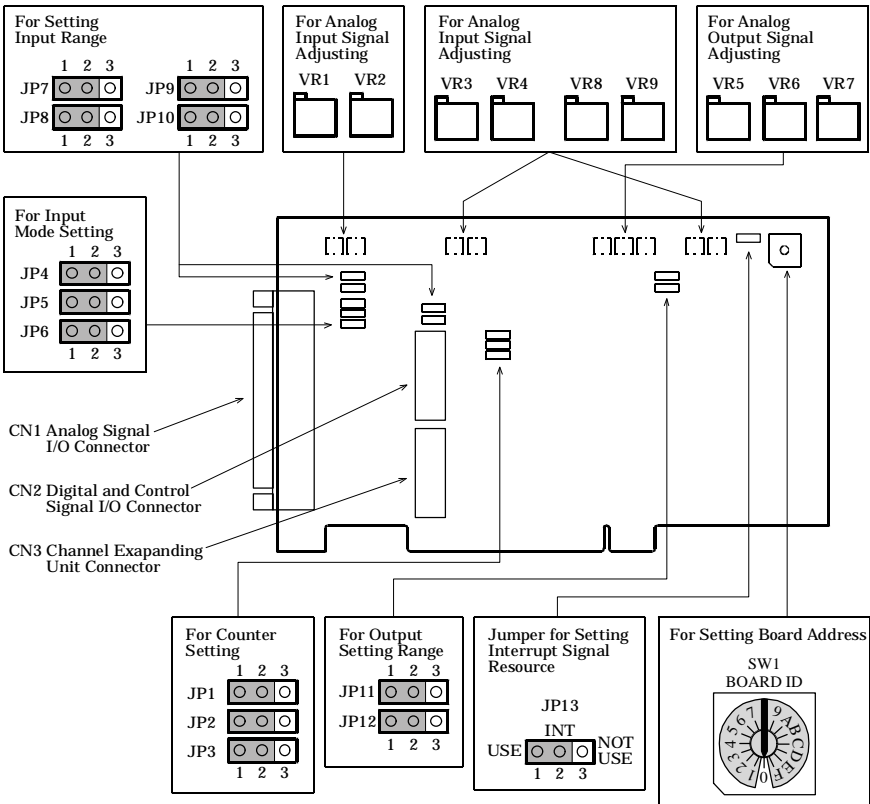

Figure 2.2. AD12-16U(PCI)E Component Locations and Default Settings

3. AD16-16(PCI)E:

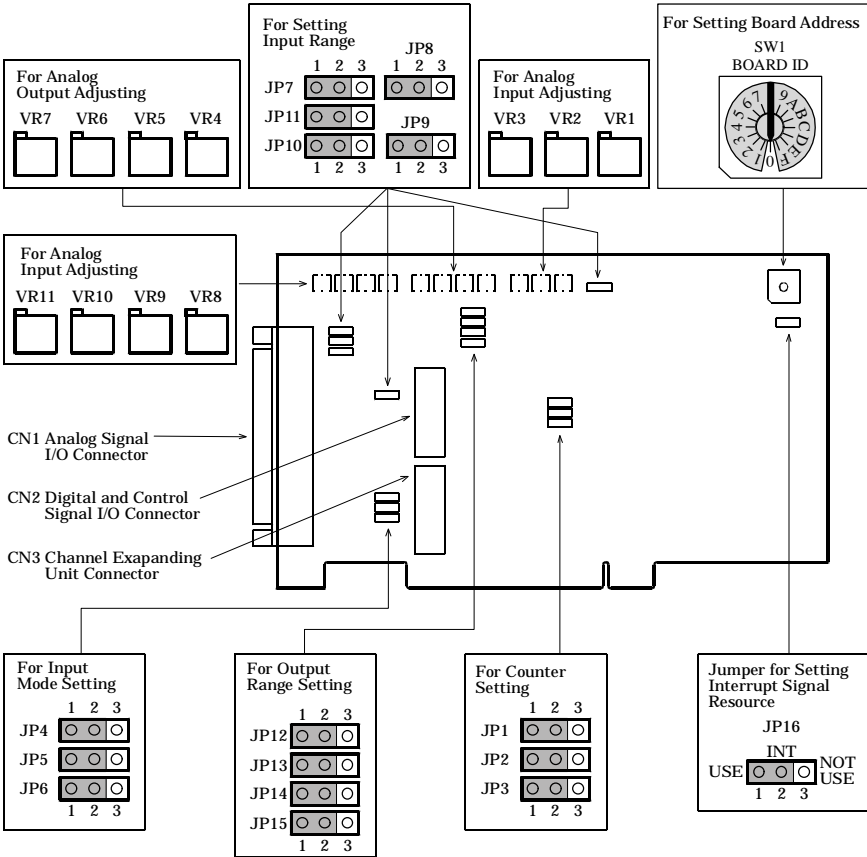

Figure 2.3. AD16-16(PCI)E Component Locations and Default Settings

Setting the Board ID

If you install two or more boards of a same type on one personal computer, set their respective board IDs to distinguish them. Assign a different value to each of the boards.

The board IDs from 0 to F can be set to identify up to sixteen boards.

Setting procedure

To set the board ID, use the rotary switch on the board. Turn the SW1 knob to set the board ID as shown below.

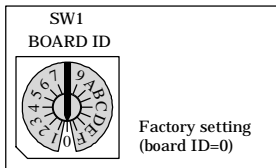

Figure 2.4. Board ID Setting (SW1)

Setting the Interrupt use

If you don't use the Interrupt function, to save the Interrupt resources of PC, you can let recognize to the PC the AD12-16(PCI)E, AD12-16U(PCI)E or AD16-16(PCI)E as no-interrupt function board.

In case of interrupt use, this board is assigned the interrupt level from PC.

Setup when interrupt is used	Setup when interrupt is not used
[AD12-16(PCI)E] uses JP12 [AD12-16U(PCI)E] uses JP13 [AD16-16(PCI)E] uses JP16	[AD12-16(PCI)E] uses JP12 [AD12-16U(PCI)E] uses JP13 [AD16-16(PCI)E] uses JP16
INT USE <input type="checkbox"/> <input type="checkbox"/> <input type="checkbox"/> NOT USE 1 2 3	INT USE <input checked="" type="checkbox"/> <input type="checkbox"/> <input type="checkbox"/> NOT USE 1 2 3

Figure 2.5. Setting the Interrupt Use

Analog Input Settings

Analog input settings include input mode setting and input range setting.

Set Input Mode

Input mode setting selects the input signal connection method. Jumpers JP4, JP5 and JP6 are used for setting the input mode. All the AD12-16(PCI)E, AD12-16U(PCI)E and AD16-16(PCI)E share the same settings. The following figure shows how to set the input mode.

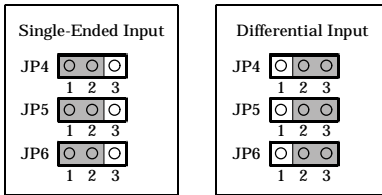

Figure 2.6. Setting Input Mode

Note!

Do not set the jumper at any other setting. It may be cause of malfunction.

Set Input Range

Input range setting selects a voltage range of analog input signals. The board converts the signal within the range into a digital data according to the resolution. The input range is the same for all input channels. You cannot set individual input range for each channel. Figures 2.7. , 2.8. and 2.9. show the jumper settings of the boards.

AD12-16(PC)E:

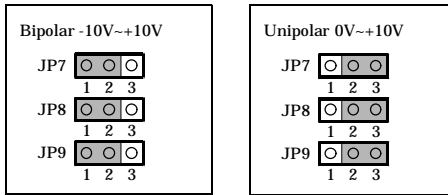

Figure 2.7. AD12-16(PC)E's Input Range Settings

AD12-16U(PC)E:

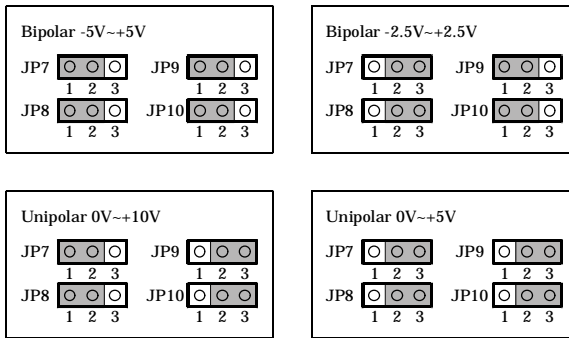

Figure 2.8. AD12-16U(PC)E's Input Range Settings

AD16-16(PCDE):

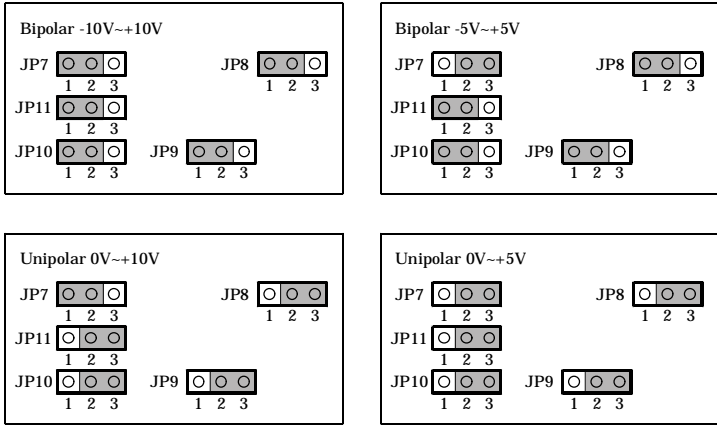

Figure 2.9. AD16-16(PCI)E's Input Range Settings

Analog Output Setting

Use jumpers to select an analog output voltage range.

Set output range

Figures 2.10. , 2.11. and 2.12. show the jumper settings of various output voltage ranges.

AD12-16(PCI)E:

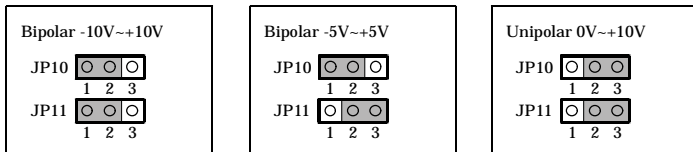

Figure 2.10. AD12-16(PCI)E's Output Range Settings

AD12-16U(PCI)E:

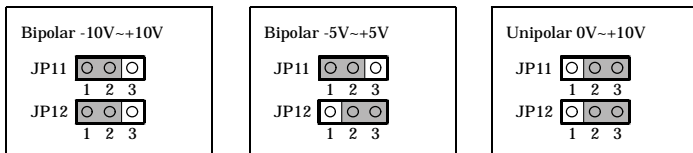

Figure 2.11. AD12-16U(PCI)E's Output Range Settings

AD16-16(PCI)E:

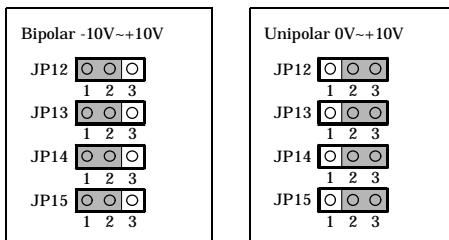

Figure 2.12. AD16-16(PCI)E's Output Range Settings

Note!

Do not set the jumper to other setting. Doing so may cause a malfunction.

Set Counter and Digital I/O

The AD12-16(PCI)E, AD12-16U(PCI)E and AD16-16(PCI)E boards have integrated an i8254 compatible counter into its circuit. Because some digital I/O signals share the same connector pins with these counter signals, this section shows you how to set the jumpers for the control and output signals (counter output signal, gate signal, clock input signal) of this counter.

Jumper JP1 is used to select an output signal for connector CN2's pin 10.

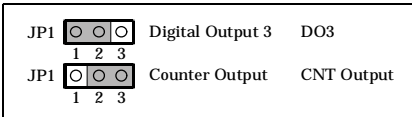

Figure 2.13. Jump the CN2 Pin10 as DO3 or CNT Output

Jumper JP2 is used to select the gate control signal of the i8254 either from the internal circuit or from the connector CN2's pin 4, the DI1/CNT Gate signal.

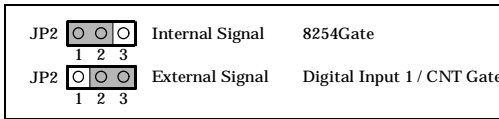

Figure 2.14. Select Gate Signal of Counter 1 and 2

Jumper JP3 is used to set the clock signal of the i8254's counter 1 either as the count output of the i8254's counter 0 or from the connector CN2's pin 12, the DI2/CNT Clock signal.

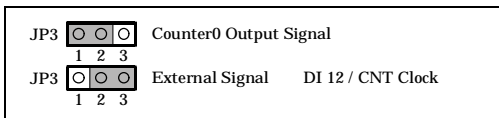

Figure 2.15. Select Clock Signal of Counter

Note!

Only TTL level signals can be used for the counters.

3. Board Setup

The board setup method varies according to the operating system being used.

Use CONTEC Windows Software Products

For MS Windows OS systems, we recommend you to use our Windows software products (optional).

< Examples of CONTEC software products for Windows >

- Driver Software Package (Option) API-PAC(W32)
- ActiveX Component Package (Option) ACX-PAC(W32)

Please follow the setup instructions of the User's manual shipped with the software products and/or the help files of the package to setup our interface board(s) to your system.

For details of CONTEC software products, please contact our sales agencies.

When Not Using CONTEC Software for Windows

When you don't use CONTEC software for Windows, the board setup procedure varies with each OS.

For Windows 98 Systems

Every PCI bus board/device will be automatically assigned required system resources, such as I/O address range and interrupt level, by the system whenever the system is turned on.

Under Windows 98 OS, before using the board you should register the board information, such as assigned resources, to the OS. This procedure is called hardware installation. After the hardware installation is done, Windows 98 can then manage the board information from its registers.

Following is hardware installation steps. After finished the installation, you are supposed to confirm the registered board information from Windows 98 registers.

This procedure does not install board driver(s). Lately you should install driver program(s) yourself.

Hardware Installation Steps

- (1) Set the board ID.
- (2) Be sure the power of the personal computer is turned off; then plug the board into a PCI bus slot in the system.
- (3) Turn the personal computer ON to start up Windows 98.
- (4) Because this is the first time Windows 98 detected the board from the system, Windows 98 will display a message of [New Hardware] on the screen and start run an [Add New Hardware Wizard] program. After you find a message of [PCI Multimedia Device] from the program window, click [Next>] to continue.
- (5) In the next dialog box, select a radio button of [Search for the best driver for your device. (Recommended).], then click [Next>] to continue.
- (6) In the next dialog box, select both of the [Floppy disk drives (F)] and [Specify Location (L)] check boxes, then enter the

drive name, such as "A:", and the directory name, WIN95, into the [Location] field.

Insert the attached FD into the disk drive, then click [Next>] to continue.

- (7) In the [Windows driver file search for the device] dialog box, check that "CONTEC Co., Ltd.-Board Name" and "AIO_PIO.INF" in the [Location of driver] has been listed, then click [Next>] to continue.
- (8) In the next dialog box, you will find a message of "Windows has finished installing the software that your new hardware device requires." Then you click [Finish] to complete the installation of the board. After completed the board installation, you are supposed to confirm the registered board information from Windows 98 registers. The "Checking resources" part of this section explains you how to do it.

Method of installing two or more boards:

- (1) Install the first board correctly.
- (2) Be sure to complete installation of the first board before attempting to install a second one.
- (3) Exit Windows 98 and turn the personal computer off.
- (4) Set the board ID of the second board that should be different from the first one. Then plug the board into a PCI bus slot.
- (5) Turn the personal computer on and start the Windows 98 again.
- (6) Windows 98 will display a message of [New Hardware] on the screen and start run an [Add New Hardware Wizard] program. After you find a message of [CONTEC Co., Ltd.-Board Name] from the program window, click [Next>] to continue.
- (7) In the next dialog box, select a radio button of [Display a list of all the drivers in a specific location, so you can select the driver you want.], then click [Next>] to continue.
- (8) From the [Models] window, select "CONTEC Co., Ltd.-Board Name" and click [Next>] to continue.
- (9) In the [Windows driver file search for the device] dialog box, there should be the message of "CONTEC Co., Ltd.-Board

Name" and "CONTEC~*.INF" in the [Location of driver] window, after confirmed this message click [Next>] to continue. (A number which is assigned by the OS will replace the "*" mark.)

- (10) In the next dialog box, you will find a message of "Windows has finished installing the software that your new hardware device requires." Then you click [Finish] to complete the installation of the board. After completed the board installation, you are supposed to confirm the registered board information from Windows 98 registers again.

For installing the third board and any additional boards, follow the same steps as those for installing a second board. Before you can install a third board or additional boards, all the boards that are already installed must be in their PCI bus slots.

Notes!

- *The second board cannot be properly installed unless the resources (I/O addresses and interrupt level) for the board can be allocated. Before attempting to install the second board, first determine what PC resources are free to use.*
- *The resources used by each board do not depend on the location of the PCI bus slot or the board itself. If you remove two or more boards that have already been installed and then remount one of them on the computer, it is unknown that which one of the sets of resources previously assigned to the two boards is assigned to the remounted board. In this case, you must check the resource settings.*

Checking resources

Follow the steps below to check the assigned resources managed by the OS.

- (1) Double-click on the [System] option in [Control Panel] to open the [System Properties] property sheet. Select the [Device Manager] tab.
- (2) Click [Multi-function adapters] folder.
- (3) Click [CONTEC Co., Ltd.-Board Name] folder to display its properties.
- (4) Select the [Resources] tab to check the device type, resource settings, and the conflicting device list.

For Windows 95 Systems

Every PCI bus board/device will be automatically assigned required system resources, such as I/O address range and interrupt level, by the system whenever the system is turned on.

Under Windows 95 OS, before using the board you should register the board information, such as assigned resources, to the OS. This procedure is called hardware installation. After the hardware installation is done, Windows 95 can then manage the board information from its registers.

Following is hardware installation steps. After finished the installation, you are supposed to confirm the registered board information from Windows 95 registers.

This procedure does not install board driver(s). Lately you should install driver program(s) yourself.

Procedure of Hardware Installation

<Checking the OS version>

The procedure of installing the board is different from the Windows 95 versions. Before any installation, you must check the version of Windows 95 that you are using.

- (1) Open [Control Panel] from [My Computer].
- (2) Double-click on the [System] option to open the [System Properties] property sheet.
- (3) Check the "System:" number displayed on the [General] page.
System : Microsoft Windows 95
4.00.950

The versions of Windows 95 include 4.00.950, 4.00.950a, 4.00.950B and 4.00.950C. The board setup method depends on the version of Windows 95 that is being used.

For Windows 95 version 4.00.950 or 4.00.950a systems:

- (1) Set the board ID.
- (2) Be sure the power of the personal computer is turned off; then plug the board into a PCI bus slot in the system.
- (3) Turn the personal computer ON to start up Windows 95.
- (4) Windows 95 will come up with the [New Hardware] detection dialog box. Select [Multimedia Device: Select which driver you want to install for your new hardware.] and then [Driver from disk provided by hardware manufacturer].
- (5) In the [Install From Disk] dialog box, insert the attached FD into the disk drive, enter the drive name and directory name in the [Copy Distributed File From] field, then click [OK]. This completes installation of the board.
- (6) Follow the instructions on the screen to complete installation of the board. After completed the board installation, you are supposed to confirm the registered board information from Windows 95 registers. The "Checking resources" part of this section explains you how to do it.

For Windows 95 version 4.00.950B or 4.00.950C systems:

- (1) Set the board ID.
- (2) Be sure to check that the personal computer is off; then plug the board into a PCI bus slot in the system.
- (3) Turn the personal computer on to start up Windows 95.
- (4) Because this is the first time Windows 95 detected the board from the system, Windows 95 will display a message of [New Hardware] on the screen and start run an [Device Driver Wizard] program. After you find a message of [PCI Multimedia Device] from the program window, click [Next>] to continue.
- (5) In the next dialog box, select [Specify Location...]. Insert the attached FD into a drive, enter the drive name and directory name (WIN95) in the [Location] field, then click [OK].
- (6) In the next dialog box, there should be a message of "Updated driver found for this device". After confirmed this message

you click [End]. This completes installation of the board. After completed the board installation, you are supposed to confirm the registered board information from Windows 95 registers. The "Checking resources" part of this section explains you how to do it.

**Method of installing two or more boards
(For Windows 95 version 4.00.950 or 4.00.950a system) :**

- (1) Install the first board correctly.
- (2) Be sure to complete installation of the first board before attempting to install the second one.
- (3) Exit Windows 95 and turn the personal computer off.
- (4) Check the board ID of the second board that should be different from the first one. Then plug the board into a PCI bus slot.
- (5) Turn the personal computer on again to start up Windows 95.
- (6) Windows 95 will come up with the [New Hardware] detection dialog box. In [Multimedia Device: Select which driver you want to install for your new hardware.], select [Select from List].
- (7) The [Select Hardware Type] dialog box will then appear. In [Select Hardware Type to Install] windows, select [Other Devices].
- (8) In the [Select Device] dialog box, select [CONTEC] from [Manufacturers] window and select [CONTEC Co., Ltd.-Board Name] from [Models] window.
- (9) A [Change System Settings] dialog box appears. Follow the messages to restart the computer.
- (10) When Windows 95 is restarted, installation of the second board is completed. Check the assigned resources again.

For installing the third board and any additional boards, follow the same steps as those for installing a second board. Before you can install a third board or additional boards, all the boards that are already installed must be in PCI bus slots.

Notes!

- *The second board cannot be properly installed unless the resources (I/O addresses and interrupt level) for the board can be allocated. Before attempting to install the second board, first determine what PC resources are free.*
- *The resources used for each board do not depend on the location of the PCI bus slot or the board itself. If you remove two or more boards that have already been installed and then re-mount one of them on the computer, it is unknown which one of the sets of resources previously assigned to the two boards is assigned to the re-mounted board. In this case, re-check the resource settings.*

Method of installing two or more Boards (For Windows 95 version 4.00.950B or 4.00.950C systems) :

- (1) Install the first board correctly.
- (2) Be sure to complete installation of the first board before attempting to install the second one.
- (3) Exit Windows 95 and turn the personal computer OFF.
- (4) Check the board ID of the second board, then plug it into a PCI bus slot. Assign to the second board a board ID different from the ID assigned to the first board.
- (5) Turn the personal computer on again to start up Windows 95.
- (6) The OS will then automatically install the second board. When the installation has been completed, check the assigned resources again.

For installing the third board and any additional boards, follow the same steps as those for installing a second board. Before you can install a third board or additional boards, all the boards that are already installed must be in PCI bus slots.

Notes!

- *The second board cannot be properly installed unless the resources (I/O addresses and interrupt level) for the board can be allocated. Before attempting to install a second board, first determine which PC resources are free.*
- *The resources used for each board do not depend on the location of the PCI bus slot or the board itself. If you remove two or*

more boards that have already been installed and then re-mount one of them on the computer, it is unknown which one of the sets of resources previously assigned to the two boards is assigned to the re-mounted board. In this case, re-check the resource settings.

Checking resources

Follow the steps below to check the assigned resources managed by the OS.

- (1) Double-click on the [System] option in [Control Panel] to open the [System Properties] property sheet. Select the [Device Manager] tab.
- (2) Click on the [Multi-function adapters] folder.
- (3) Click on the [CONTEC Co., Ltd.-Board Name] folder to display its properties.
- (4) Select the [Resources] tab to check the device type, resource settings, and the conflicting device list.

For other OS systems

We use MS-DOS as an example to show how to use the board under other operation systems, in addition of the Windows OS. Refer the MS-DOS programs in the attached FD.

For a PCI bus board, the system will automatically assign usable resources to the board. Refer the following procedure to confirm the assigned resources.

Procedure

- (1) Set the board ID.
- (2) Be sure that the personal computer is off; then plug the board into a PCI bus slot in the personal computer.
- (3) Turn the personal computer ON to start up MS-DOS.
- (4) Copy the programs that are under the DOS directory of the attached FD to a directory of your HDD.
- (5) Execute the AIOPCI.EXE resource confirmation program.
- (6) Check the I/O addresses and interrupt level (IRQ) displayed on the screen.

Note!

When you use the board under a non plug-and-play OS like MS-DOS, be sure that [PnP OS] is either [disabled] or set to [not to use] in the PC's BIOS setup. If this is set to [Windows 95], for example, the board might not be recognized properly.

4. External Connections

External Connections

You are now ready to connect the wires that carry the signals from the board.

A 37-pin D type female connector (CN1) interfaces the analog signals to the appropriate external devices and a 16-pin male connector (CN2) connects the digital I/O signals from the external devices.

Note!

Connector CN3 is only for optional terminal units and is not available for user connections.

Analog Signal Connection

Figure 16 shows the definition of the CN1 connector for all the AD12-16(PCI)E, AD12-16U(PCI)E and AD16-16(PCI)E boards.

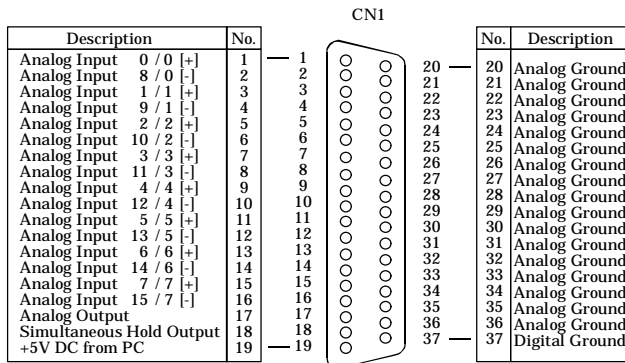

Figure 4.1. CN1 Signal Configuration

Analog Input

The Analog Input 0~15 are the input channel names of single-ended input. The Analog Input 0[+]~7[+] and the Analog Input 0[-]~7[-] are the input channel names of differential input.

Analog Output

The Analog Output pin outputs a single-ended voltage signal.

Simultaneous Hold Output

This signal is a control signal for the optional ATSS-16 terminal unit.

Analog Ground

The Analog ground signal (common to the analog I/O signals)

Digital Ground

The Digital ground signal (common to the simultaneous sampling signal and +5V power output)

+5V DC

This is the power supply line from your PC. The power capacity is 3A.

Notes!

- Do not short the output signals to the analog ground, digital ground and/or power line.
- Do not short the power line to the analog ground and/or digital ground.

Digital Signal Connection

Figure 17 shows the definition of the CN2 connector for all the AD12-16(PCI)E, AD12-16U(PCI)E and AD16-16(PCI)E boards.

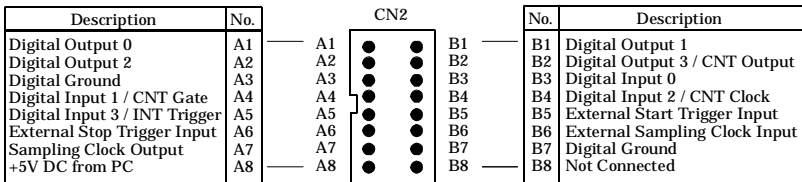

Figure 4.2. CN2 Signal Configuration

Digital Output

Digital Output 0 - Digital Output 3 are TTL level digital output signals.

Note!

The Digital Output 3 shares the same pin with the CNT Output (counters output signal) so that only one of these two signals can be outputted simultaneously.

Digital Input

Digital Input 0- Digital Input 3 are TTL level digital input signals. Digital Input 1 is also used as CNT Gate (counter gate control input). Digital Input 2 is also used as CNT Clock (counter clock input). Digital Input 3 is also used as INT Trigger (interrupt trigger input).

A/D Control Signals

External Start Trigger Input is a TTL level input signal and can start the analog input samplings.

External Stop Trigger Input is a TTL level input signal and can be used to end the analog input samplings.

External Sampling Clock Input is also a TTL level clock signal for the analog to digital converting operation.

Sampling Clock Output outputs the sampling clock of the analog input circuit and is also a TTL level signal.

Digital Ground

Digital ground commons to all digital signals and power output.

+5V DC

Power output line from your PC. The power capacity is 1A.

Notes!

- *Do not short the output signals to the analog ground, digital ground and/or power line.*
- *Do not short the power line to the analog ground and/or digital ground.*

Signal Connection

Analog Input Connection

There are two analog input mode: the Single-ended input and the Differential input. Here we give some examples of analog input connections by using flat cable or shield cable.

Single-ended Input

The following figure shows an example of flat cable connection. Each signal source is connected to one analog input channel and the signal common to analog ground pin of CN1.

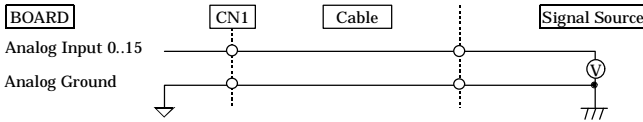

Figure 4.3. Single-ended Input Connection (Flat Cable)

The following figure shows an example of shield cable connection. When the distance between the signal source and the board is long or you want to increase the noise tolerance, a shield cable is suggested. Connect the signal by the core wire and common signal by the shield braids.

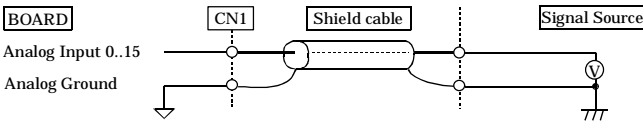

Figure 4.4. Single-ended Input Connection (Shield Cable)

Notes!

- If the signal source contains over 1MHz signals, the signal may effect the cross-talk noise between channels.
- If the board and the signal source receive noise or the distance between the board and the signal source is too long, data may not be input properly.
- An input analog signal should not exceed the maximum input voltage (relate to the board analog ground). If it exceeds the maximum voltage, the board may be damaged.
- Connect all the unused analog input channels to analog ground.

Differential Input

The following figure shows an example of flat cable connection. Each signal source is connected to a [+] pin of analog input channel and the signal common of this source to the [-] pin of this input channel of CN1. In addition, the signal common must be connected to the pin of the analog ground of CN1 by a third wire.

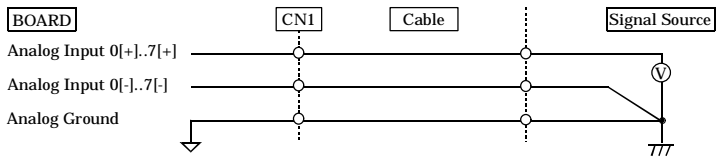
**Figure 4.5. Differential Input Connection (Flat Cable)**

The following figure shows an example of 2-wire shielded cable connection. When the distance between the signal source and the board is long or you want to increase the noise tolerance, a shield cable connection is preferred. Each signal source is connected to a [+] pin of analog input channel and the signal common of this source to the [-] pin of this input channel of CN1. In addition, the signal common must be connected to the pin of the analog ground of CN1 by the shielded braids.

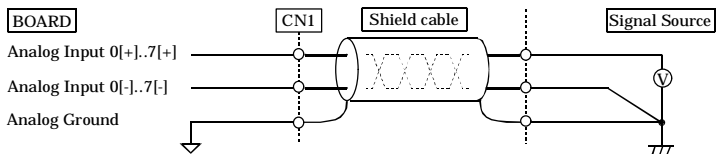
**Figure 4.6. Differential Input Connection (Shield Cable)**

Notes!

- *If the signal source contains over 1MHz signals, the signal may effect the cross-talk noise between channels.*
- *The input data would be uncertain If the analog ground is not connected.*
- *If the board and the signal source receive noise or the distance between the board and the signal source is too long, data may not be input properly.*
- *The input voltage from the [+] input or [-] input should not exceed the maximum input voltage (based on the board analog ground). If it exceeds the maximum voltage, the board may be damaged.*
- *Because the input data will be uncertain if the [+] pin or the [-] pin of CN1 is not connected, all the unused input pins of CN1 should be connected to the analog ground, AGND.*

Analog Output Connection

This section shows how to connect the analog output signal by using a flat cable or a shielded cable.

The following figure shows an example of flat cable connection.

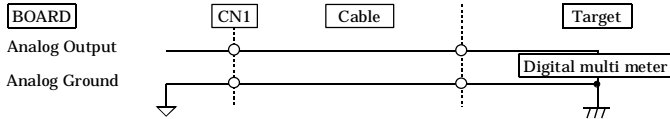

Figure 4.7. Analog Output Connection (Flat Cable)

If the distance between the signal source and the board is long or if you want to increase the noise tolerance, a shield cable connection is strongly recommended.

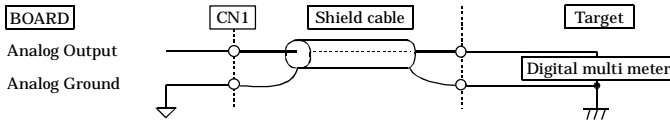

Figure 4.8. Analog Output Connection (Shield Cable)

Notes!

- If the board or the connected wire receives noise, or the distance between the board and the target is long, data may not be outputted properly.
- For analog output signal, the current capacity is $\pm 5\text{mA}$ (Max.). Check the specification of the connected device before connecting the board.
- Do not short the analog output signal to analog ground, digital ground, and/or power line. Doing so may damage the board.

Digital I/O Connection

The digital I/O signals and the control signals are interfaced through the connector CN2. User can use an optional cable DT/E1 or DT/E2 (with bracket and a 15-pin D type female connector) to connect these signals to your external devices.

All the digital I/O signals and control signals are TTL level signals.

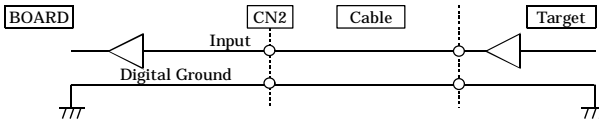

Figure 4.9. Digital Input Connection

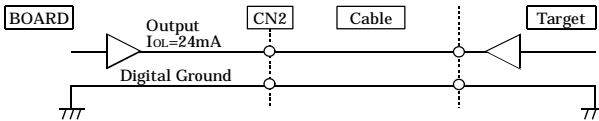

Figure 4.10. Digital Output Connection

Note!

Do not short the output signals to analog ground, digital ground, and/or power line. Doing so may damage the board.

5. Operation Functions

Here we are going to discuss some operation functions of AD12-16(PCI)E, AD12-16U(PCI)E and AD16-16(PCI)E boards.

Analog Input Function (A/D)

This function converts analog signals to digital data depending on the resolution. The converted data are stored in the on board memory in the order of conversion. You can set conversion start condition, stop condition, sampling period and other parameters for your analog input function.

The following shows the parameters in general.

- * Input channel / Input gain
 - Single channel --- Input gain
 - Multichannels --- Input gain --- Input channel order
- * Scan clock / Sampling clock
 - Scan clock --- Internal clock --- Sampling period
 - Scan clock --- External clock signal
- * Sampling start condition
 - Software
 - Converted data comparison --- Comparison condition --- No. of trigger delays
 - External signal rising edge --- No. of trigger delays
 - External signal falling edge --- No. of trigger delays
- * Sampling stop condition
 - Store ending --- No. of samplings --- No. of delayed samplings
 - Converted data comparison --- Comparison condition --- No. of samplings --- No. of delayed samplings
 - External signal rising edge --- No. of samplings --- No. of delayed samplings
 - External signal falling edge --- No. of samplings --- No. of delayed samplings
- * Sampling repeat mode
 - Set No. of times --- No. of repeats
 - No limits
- * Buffer memory format
 - FIFO format
 - Ring format
- * Converted data format
- * Over range detection function
- * Input mode selection
- * Simultaneous sampling function
- * Expanding Input Channel function

Input Channels

There are two modes - single channel mode and multichannel mode.

Under the single channel mode, this board converts only one channel of input signal. You must specify this channel. You can program the Input gain for this input signal in advance. With the sampling period, A/D conversions are done for a specified number of times and the converted data are stored in the on board memory.

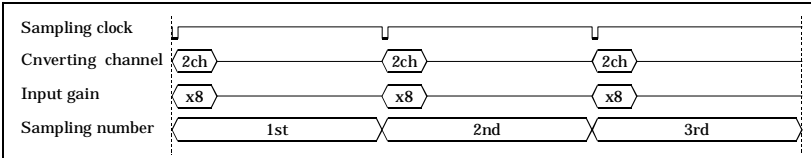

Figure 5.1. Single Channel Mode Operation

Under the multichannel mode, this board converts multiple channels of input signals for each sampling period. You must program the input channels and the converting sequence in advance. In one scanning the input sequence can be in any order and the input channel can be repeated. You can also set the channel scan period and control the time difference between the channels for every 25 nsec. Additionally, each channel can be assigned an independent Input gain. In each sampling period, this board scans all the specified channels and stores the converted data into the on board memory in the converting order.

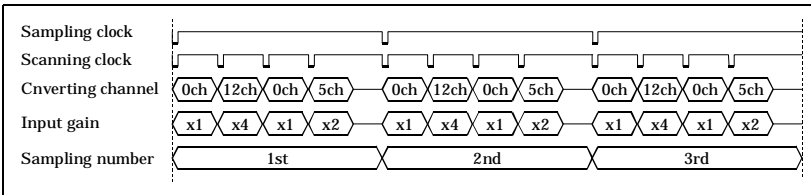

Figure 5.2. Multichannel Mode Operation

Note!

You cannot program an Input gain for AD12-16U(PCI)E, and AD16-16(PCI)E boards.

Sampling Period

The sampling clock determines the sampling period. You can select either an internal or external clock signal.

The internal clock signal comes from a clock generator. You can program the clock generator with a minimum step period of 25 nsec.

The external clock signal comes from the interface connector CN2. The falling edge of this signal is used as the sampling clock.

Regardless of whether you use an internal clock or an external clock, if the next sampling clock is received during a conversion (during channel scan), a sampling clock error occurs. If this error occurs, the converted data at this moment will be stored in the memory, the operation will be terminated from the next channel and the sampling clock error status will be set. Reset this status by executing the board reset command.

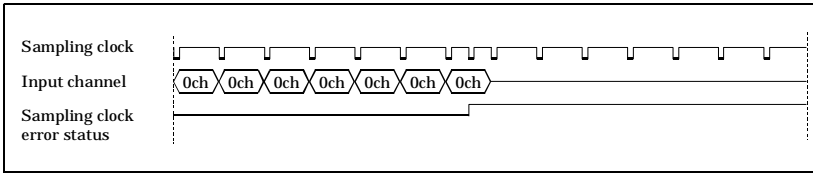

Figure 5.3. Example of Sampling Clock Error of Single Channel

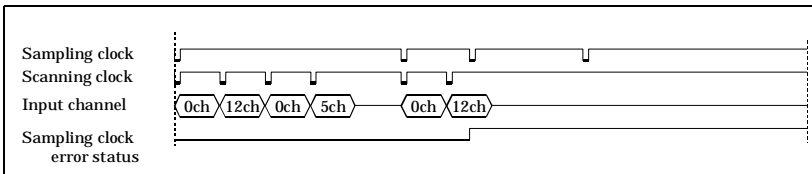

Figure 5.4. Example of Sampling Clock Error of Multichannels

Start Sampling

The A/D sampling can be started by one of the following methods:

- A software command
- The value of converted data from a specified channel
- An external TTL level control signal

The sampling start and stop conditions are completely independent and can be set separately.

Software Command

Under this setting, a sampling is started by a sampling start command. The converted data is stored into the on board memory.

Value of Converted Data

Under this setting, before start the sampling, you must preset two comparison data, LEVEL 1 and LEVEL 2 with other parameters. The comparison data can be any value among the data range. (For 12-bit resolution, the data range is 0 to 4095; For 16-bit resolution, the data range is 0 to 65535.) A sampling start command then starts the operation. This board repeatedly converts and compares the converted data (from a specified channel) with the preset comparison data. Only after the converted data cross the LEVEL 1 and then the new converted data cross the LEVEL 2, the board begins to scan and sampling the preset channels, store the converted data into the on board memory until a stop condition is satisfied. Because of the two comparison data, sampling can be started at a specified input signal level, which signal can have either an upward or a downward slope with hysteresis. If you set LEVEL 1 and LEVEL 2 with the same value, sampling can be started by an input signal with dual slopes.

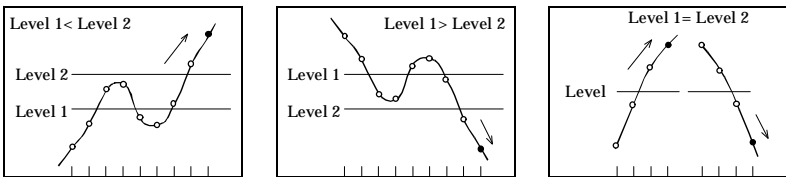

Figure 5.5. Converted Data Comparison Conditions for Starting Sampling

In addition, you can set a DC trigger or an AC trigger for comparison data. A DC trigger compares the converted data with the set value directly and an AC trigger compares the set value with the AC components of the converted data only. If the comparison result satisfies the starting condition, from the next sampling (scanning) the converted data are stored into the on board memory until a stop condition is satisfied.

TTL Level External Signal

Under this setting, after received a software start command, the board enters a state of waiting for an external control signal. If an external control signal in the preset edge direction is inputted, the board starts samplings in the predefined sampling conditions and stores the converted data in the memory.

If an external control signal is input again during a sampling operation, a start trigger error status is set. The sampling operation, however, does not stop. This error status is reset by a sampling error status reset command.

Stop Sampling

The A/D sampling can be stopped by one of the following methods:

- The number of samplings
- The value of converted data from a specified channel
- A TTL level external control signal- A software command

The sampling start and stop conditions are completely independent and can be set separately.

Number of Samplings

The board stops the samplings after storing a specified number of converted data into the on board memory.

Value of Converted Data

After converted and stored a specified number of sampling data into the on board memory, the board begins to compares the new comings of the specified channel with the preset comparison data. Same as the start condition, there are two comparison data that must be set before the start command. Only after the converted data cross the LEVEL 1 and then the new converted data cross the LEVEL 2, the board stops sampling operation. (Before the board stops samplings, the specified channels are still be sampled and the converted data are stored in the on board memory by the converting order.) Because of the two comparison data, the sampling can be stopped at an upward slope or a downward slope of an input signal with hysteresis. If you set LEVEL 1 and LEVEL 2 with the same value, the sampling can be stopped by dual slope input signal.

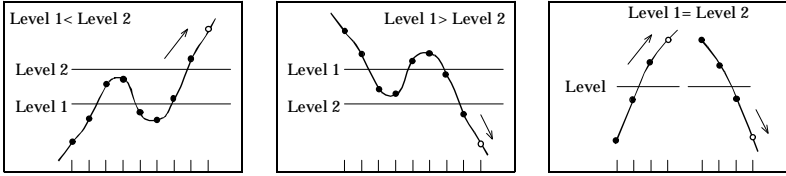

Figure 5.6. Converted Data Comparison Conditions for Stopping Sampling

In addition, you can set a DC trigger or an AC trigger for comparison data. A DC trigger compares the converted data with the set value directly and an AC trigger compares the set value with the AC components of the converted data only. If the comparison result satisfies the stop condition, the system stops sampling after the last converted (scanned) data is stored in the memory.

TTL Level External Signal

After the specified number of conversions have been exercised, a rising edge or a falling edge of an external control signal will stop the sampling (scanning) operation.

Software stop Command

A software stop command can unconditionally stop sampling operation regardless the presetting. When received a stop command, the board stops the sampling operation after stored the last converted data of this scanning into the on board memory.

The Numbers of Samplings

There are three numbers that are related to the sampling control: the number of trigger delays, number of samplings, and number of delayed samplings.

Trigger Delays

This number determines how many samplings should be eliminated after the start condition has been satisfied. This number can be set only for two start conditions of value of converted data and external TTL signal. After the start condition has been satisfied, this board start to scan the input channels but will not store the converted data into the on board memory until it finished the “Trigger Delays”

times of samplings.

Number of Samplings

The number of samplings determines the number of converted data that are stored in the on board memory. If the stop condition is the Number of samplings, this number tells when to stop the sampling. If the stop condition is the Value of the converted data or the External TTL signal, this number means the minimum number of samplings. In other words, the board will begin to evaluate the stop condition only after that many samplings have been done.

Number of Delayed Samplings

The number of delayed samplings determines the number of samplings that should be done after the sampling stop conditions are satisfied. In this case, after the sampling stop condition is satisfied (this does not apply when a sampling is stopped by a software stop command), the board will still scan the specified channels this many times and store the converted data into the on board memory before stop the sampling operation. If you set 0 for the number of delayed samplings, the board stops sampling when the sampling stop condition is satisfied.

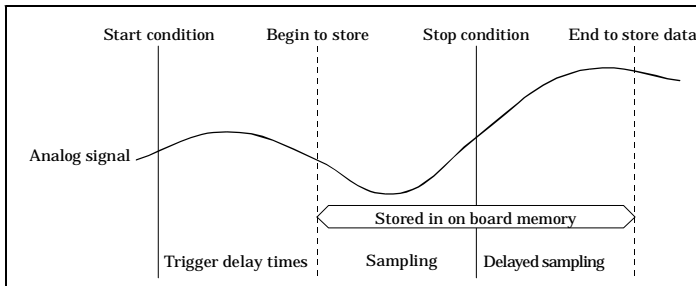

Figure 5.7. Controlling Number of Samplings

Repeat Times

If we define an operation cycle is from the sampling start to the sampling stop, the number of repeat times determines how many times that the operation cycles should be done. The following figure is an example of three repeat times.

This repeat times can be used only for value start of external TTL control signal start settings.

The board repeats the operation cycles for this many times and then stop the operation. The repeat times can be set as unlimited. In this case, the operation cycles will be repeated until a software stop command stops the sampling operation.

The converted data are stored in the on board memory by the converting order.

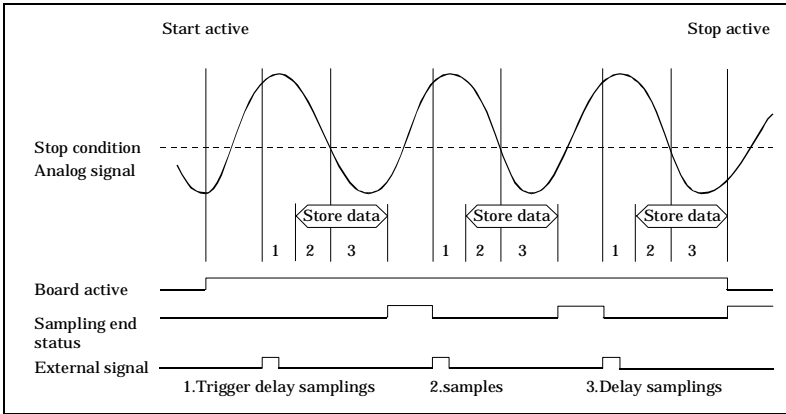

Figure 5.8. Number of Repeats

When the sampling (including delayed sampling) is stopped, the sampling end status is set. This status is reset when the next sampling start condition is satisfied or a software start command is received.

After received a software start command, the board sets an on-operation (busy) status. This status will be reset when all the sampling scans (including the repeats of scans) are finished or when a software stop command is received.

Memory Format and Memory Operation

The on board memory can store up to 256K of data. The memory format can be programmed as FIFO format or ring format. Data storage status of this memory can be monitored through the status register. In addition, you can control memory operation by a special command.

The FIFO

In the FIFO (First In First Out) format, the computer reads the data from the memory in the order that the data is written.

There are three memory status for the FIFO format: Data ready, Half full, and Overflow.

As long as the memory has stored data, the data ready status is set. When all data is read out by the computer, this status is reset. If the data in the memory occupies more than the half of the total memory size, the half full status is set. This status is reset when the data in the memory is less than half of the memory size. If the memory is full and an addition data is going to be written, the overflow status is set. If an overflow occurs, the sampling stops and the converted data (when the overflow occurred) and subsequent data are eliminated. This overflow status is reset by a buffer memory reset command.

A buffer memory reset command is designed for the FIFO format operation. This command resets the overflow status and initializes the FIFO memory.

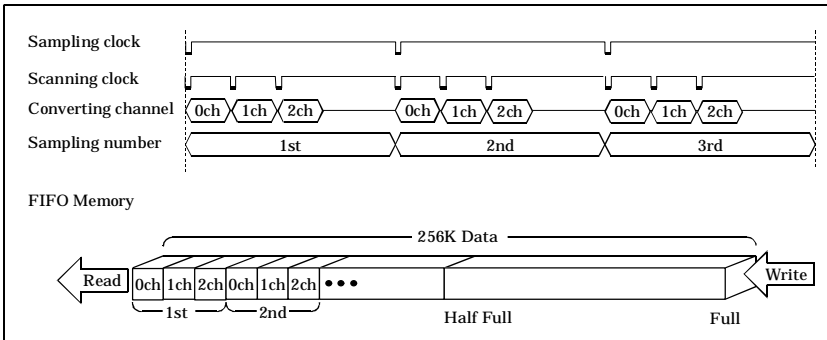

Figure 5.9. FIFO Format Buffer Memory

The Ring

In the ring format, the data area of the memory is configured as a ring. Data is written as it is converted. When the buffer is full, the new comings are overwritten to the older data from the beginning address. You can program a write address that indicates the writing position of the memory and a read address where you

read the data from the memory. This address programming function gives you the ability to specify storage positions and to read a same data many times.

There are three memory status for the ring format: Data ready, Half full, and Overflow.

After a data is written in the memory, the data ready status is set. This status is reset when you set the write address. After the write address is bigger than half of the full memory size, either due to the write address setting or due to the sequential storage, the half full status is set. This status is reset if you set the write address for less than half of the memory size. When the ring becomes full and the next write address is pointing to the preset address, a new coming data will set the overflow status. This status can be reset by the buffer memory reset command. The sampling operation will be continued even if the overflow status is set and the older data is overwritten by the new data.

The following are the memory operation commands in the ring format. The buffer memory reset command resets all the memory status and initializes the write address and the read address to 0. The write address setting command sets the write address of the memory. The read address setting command sets the read address of the memory. The write address reading command inputs the current write address and the read address reading command inputs the current read address of the memory. A triggered write address reading command inputs the address when the stop conditions are satisfied. (The address which is immediately before that start of the delayed sampling.)

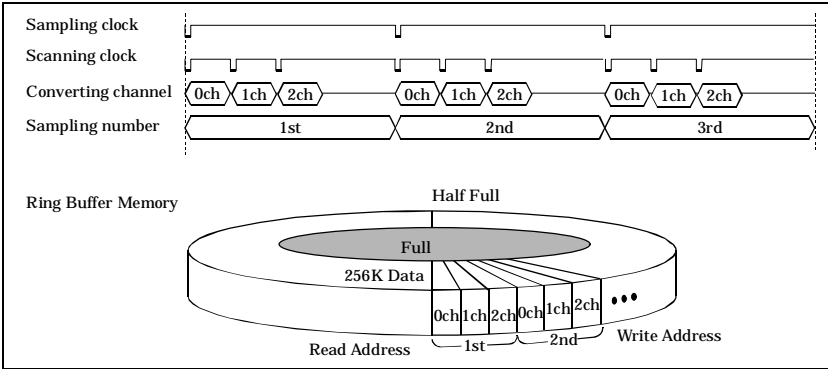

Figure 5.10. Ring Format Buffer Memory

Converted Data Format

There are two converted data formats: the Offset binary (straight binary) format and the 2’s compliment binary format. These formats are selected by software command.

The 2’s compliment binary format data is a 2’s compliment of offset binary data in 16-bit.

The following is the relation of the input voltage, the input gain and the converted data for the offset binary format:

$$\text{Data} = \frac{(\text{Voltage} \times \text{Gain} + \text{Offset}) \times 2^n}{\text{Span}} \quad n : \text{Resolution (12 or 16)}$$

Table 5.1. Input Range and Coefficient

Input range	Offset	Span
-10V to +10V	10	20
-5V to +5V	5	10
-2.5V to +2.5V	2.5	5

Input range	Offset	Span
0V to +10V	0	10
0V to +5V	0	5
0V to +2.5V	0	2.5

**Table 5.2. Examples of Converted Data
(+/-10V range/Input gain = 1)**

Input voltage (+/-10V range) (gain = 1)	12bit conversion data	
	Offset binary	2's compliment binary
+9.995V	0FFF h	07FF h
:	:	:
0.005V	0801 h	0001 h
0.000V	0800 h	0000 h
-0.005V	07FF h	FFFF h
:	:	:
-10.000V	0000 h	F800 h

Input voltage (+/-10V range) (gain = 1)	16bit conversion data	
	Offset binary	2's compliment binary
+9.99970V	FFFF h	7FFF h
:	:	:
0.00015V	8001 h	0001 h
0.00000V	8000 h	0000 h
-0.00015V	7FFF h	FFFF h
:	:	:
-10.00000V	0000 h	8000 h

Over Range Detection Function

If the value of the converted data to be stored is at the maximum or minimum, the over range status is set. This status is reset by the sampling error reset status reset command. This status will not stop the samplings.

Input Mode Selection

The input mode means the analog input signal connection method.

There are two types of input connections: single-ended input and differential input. If you can ignore the differential between the two grounds of signal source and this board and the noise composition, the single-ended input method can be used. Otherwise the differential input method is recommended.

For single-ended input, 16 input channels are available; for differential input, 8 input channels are available.

The input mode is selected by on board jumper settings.

Simultaneous Sampling Control Function

An optional unit ATSS-16 offers you the ability to add a 16 channel simultaneous sampling function to this board.

Channel Expansion Function

An optional unit ATCH-16(PCI) or ATUH-16(PCI) adds additional 16 signal-ended channels / 8 differential channels to this board.

AD12-16(PCI)E and AD16-16(PCI)E can only use the ATCH-16(PCI) while AD12-16U(PCI)E can only use the ATUH-16(PCI).

Analog Output Function (D/A)

The function D/A converts a digital data, a 12-bit data of AD12-16(PCI)E and AD12-16U(PCI)E or a 16-bit data of AD16-16(PCI)E to an analog voltage signal.

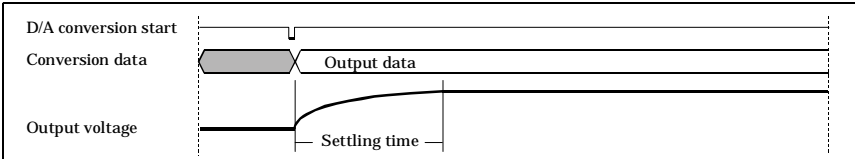

Figure 5.11. Timing Diagram for the Analog Output Operation

The format of this digital data is an offset binary (straight binary) format.

The relationship between output voltage and digital data is as follows:

$$\text{Voltage} = \frac{\text{Data} \times \text{Span}}{2^n} - \text{Offset} \quad n : \text{Resolution (12 or 16)}$$

Table 5.3. Examples of Output Voltages and Their Digital Data (12-bit)

Data	-10V to +10V span = 20V offset = 10V	-5V to +5V span = 10V offset = 5V	0V to +10V span = 10V offset = 0V
0FFh	+9.995V	+4.997V	+9.997V
:	:	:	:
0801h	+0.005V	-0.002V	+5.002V
0800h	0.000V	0.000V	+5.000V
07FFh	-0.005V	-0.002V	+4.998V
:	:	:	:
0000h	-10.000V	-5.000V	0.000V

Digital Input Function [DI]

There are 4 TTL level digital inputs. A digital signal is inputted from CN2 in positive logic. A digital input signal can also be used as a counter control signal (gate signal or clock input signal) or an interrupt trigger signal.

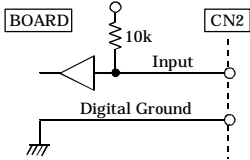

Figure 5.12. Digital Input

If a digital input (DI3) is used as an interrupt trigger signal, a falling edge of the signal will trigger an interrupt request signal and also set an interrupt trigger input status or an interrupt trigger input over status.

Digital Output Function [DO]

There are 4 TTL level digital outputs. A digital signal is outputted from CN2 in positive logic.

One of the digital output, the DO3, can be jumped to output the counter output signal.

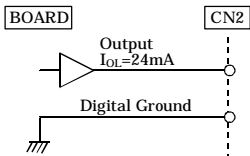

Figure 5.13. Digital Output

Counter Function

The board have been equipped an independent counter that is equivalent to the i8254.

The counter has three internal 16-bit counters. These counters are connected as shown in Figure 33. Changing the jumper

connections can change the counter configurations. The operation modes are totally programmable as the i8254.

There is a counter 2 output status that can be read by a software command to check the counter up situation or counter over run situation.

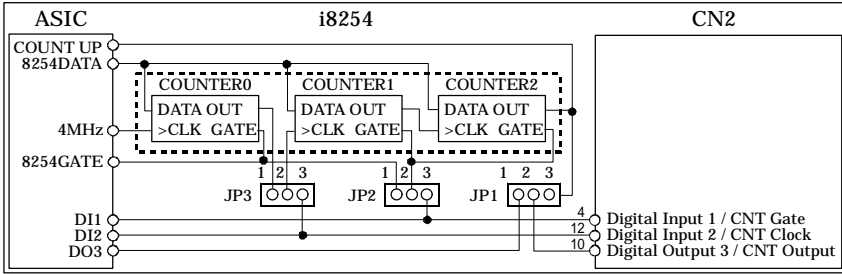

Figure 5.14. Counter Configuration

The following table shows the jumper settings.

Table 5.4. Example of Jumper Settings for Counter

<p>JP1 <input checked="" type="checkbox"/> <input checked="" type="checkbox"/> <input checked="" type="checkbox"/> 1 2 3</p> <p>JP2 <input checked="" type="checkbox"/> <input checked="" type="checkbox"/> <input type="checkbox"/> 1 2 3</p> <p>JP3 <input checked="" type="checkbox"/> <input checked="" type="checkbox"/> <input type="checkbox"/> 1 2 3</p>	<p>This setting connects three counters in the cascade mode.</p> <p>The counter 0 clock is the on board 4MHz clock signal.</p> <p>The 8254GATE gate signal of the counters is controlled by software command.</p>
<p>JP1 <input type="checkbox"/> <input type="checkbox"/> <input type="checkbox"/> 1 2 3</p> <p>JP2 <input type="checkbox"/> <input type="checkbox"/> <input type="checkbox"/> 1 2 3</p> <p>JP3 <input type="checkbox"/> <input type="checkbox"/> <input type="checkbox"/> 1 2 3</p>	<p>This setting implements a 32-bit counter (connecting Counter 1 and Counter 2) and enables the user to control the 32-bit counter externally.</p> <p>The clock and gate are inputted from CN2.</p> <p>The counter output signal is outputted to CN2.</p>
<p>JP1 <input type="checkbox"/> <input type="checkbox"/> <input type="checkbox"/> 1 2 3</p> <p>JP2 <input type="checkbox"/> <input type="checkbox"/> <input type="checkbox"/> 1 2 3</p> <p>JP3 <input checked="" type="checkbox"/> <input checked="" type="checkbox"/> <input type="checkbox"/> 1 2 3</p>	<p>This setting implements a 32-bit counter (connecting Counter 1 and Counter 2) and enables the user to control only the gate.</p> <p>The counter clock is the Counter 0 output signal.</p> <p>The gate is inputted from CN2.</p> <p>The counter output is outputted to CN2.</p>

Note!

Only the TTL level signals can be used as an external control signal for the counter.

Interrupt Function

This board supports one interrupt request of the computer. This interrupt request is selected by PC.

The following table shows the events that can generate an interrupt request signal.

Table 5.5. Interrupt Request Signal Events

Interrupt events	Description
Board operation end	The board completed all operations (including repeats).
Buffer memory data ready	Buffer memory data ready status is set.
Buffer memory half full	Buffer memory half full status is set.
Buffer memory overflow	Buffer memory overflow status is set.
Sampling end	Sampling end status is set.
Over range error	Over range error status is set.
Start trigger error	Start trigger error status is set.
Sampling clock error	Sampling clock error status is set.
Sampling start conditions are satisfied.	External start signal has been inputted, or comparison start conditions are satisfied.
Sampling stop conditions are satisfied.	External stop signal has been input, or comparison stop conditions are satisfied.
Channel scan end	Channel scanning ended (multichannels only).
i8254 count-up	i8254 count-up status is set.
i8254 count-overrun	A count-up signal is common when the i8254 count-up status has already been set.
Interrupt trigger input	Interrupt trigger input status is set (Fall edge).
Interrupt trigger input overrun	An Interrupt trigger is inputted when the interrupt trigger input status has already been set.

Multiple interrupt events can be selected to generate a specified interrupt request.

An interrupt event will also be stored in the board interrupt event register. This register can be read or reset by a specially designed software command set.

If multiple events are selected for an interrupt request, the event/events will be set in an interrupt event register. The interrupt handler program can check this registers to determine which service should be done. If this register indicates that there are more than one event request services but only one event has been served, when this served event is reset, the other unserved event/events will generate another interrupt request.

6. Demonstration Program

The demonstration programs that are supplied with the diskette illustrate the basic uses of the AD12-16(PCI)E, AD12-16U(PCI)E and AD16-16(PCI)E boards.

The diskette contains the following programs and files:

Table 6.1. Contents of the Diskette

File Name	Description
AI. EXE	Analog input function demonstration program (for IBM PC-AT compatible)
AI98. EXE	Analog input function demonstration program (for NEC PC-98 series)
AI. SET	Analog input condition setting file
AO. EXE	Analog output function demonstration program
DI. EXE	Digital input function demonstration program
DO. EXE	Digital output function demonstration program
CNT. EXE	Counter function demonstration program

Preparation

Set the board as the default settings.

Make your connections for the board.

Turn on the computer and start the demonstration programs under the MS-DOS.

Analog Input

Set the sampling conditions and then start the analog to digital conversions under the conditions. The conversion results are displayed on the CRT of the computer. If a setting file is specified, this program samples the input signals under the file specified conditions.

Format: **AI -B** [*Board ID*] **-F** [*filename*]

Option: **-B:** Board ID (default is 0.)

-F: To specify a condition setting file.

Examples:

```
>AI
```

(Start the program without a condition setting file)

```
>AI -FAI
```

(Start the program with a condition setting file AI.SET)

We suppose you to use a battery or a standard voltage generator as your input signal source.

Note!

- *If the external control signals are used, these signals must be TTL level signals.*

Analog Output

Output a specified voltage signal. The outputted voltage and the responding digital data, depending on the resolution, are displayed on the CRT of the computer.

Format: **AO -B** [Board ID] **-R** [Range] **-V** [Voltage]

Option: **-B:** Board ID (default is 0.)

-R: Output Range

 B10 : ±10V Range

 B5 : ±5V Range

 U10 : 0~10V Range

-V: Output Voltage Value

Example of outputting 1.25V voltage under ±5V range for a 12-bit resolution D/A converter.

```
>AO -RB5 -V1.25
OUTPUT RANGE       -5V to +5V
OUTPUT VOLTAGE     1.2500V
OUTPUT DATA       0A00H
>
```

You can confirm this outputted voltage signal by a multi meter.

Note!

The output range must meet the jumper setting.

Digital Input

Input the four digital inputs and display these inputs on the CRT of the computer.

Format: **DI -B** [*Board ID*]

Option: **-B:** Board ID (default is 0.)

Example of digital input:

```
>DI
DIGITAL INPUT  DI3[1], DI2[0], DI1[0], DI0[1]
>
```

Digital Output

Output the specified digital data and display these data on the CRT of the computer.

Format: **DO -B** [*Board ID*] [DO3], [DO2], [DO1], [DO0]

Option: **-B:** Board ID (default is 0.)

Example of digital output:

```
>DO 1, 1, 0, 1
DIGITAL OUTPUT DO3[1], DO2[1], DO1[0], DO0[1]
>
```

Counter

Set the counter (an i8254 compatible) mode as mode 2 and the count data to generate a 1 sec frequency counter output. Monitor the count up status and display on the CRT of the computer for each count up.

Format: **CNT -B** [*Board ID*]

Option: **-B:** Board ID (default is 0.)

Example of this demonstration program:

```
>CNT
  1:COUNT UP!
  2:COUNT UP!
      :
 10:COUNT UP!
>
```

7. Calibration Program

This program calibrates the analog input and analog output functions under MS-DOS.

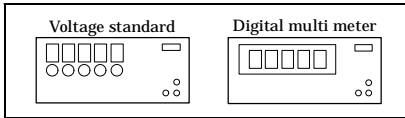

Figure 7.1. Instruments for Calibration

Each board of the AD12-16(PCI)E, AD12-16U(PCI)E or AD16-16(PCI)E has different calibration procedures.

You must follow the instructions of this calibration program to calibration. A standard voltage generator and a multi meter are used for this calibration. These devices, however, should have a better resolution and accuracy than the calibrated board.

Format: **CAL -B** [*Board ID*]

Option: **-B:** Board ID (default is 0.)

Notes!

- *If your PC is NEC PC-98 series, you must use CAL98.EXE instead of CAL.EXE.*
- *Do not exercise any operation out of the instructions of this program. Doing so may damage the board.*

Potentiometers for Analog Input Circuit Adjustment

The offset voltage and gain of analog input circuit have been calibrated at the factory. In case you may need to readjust the analog input circuit, the following tables show you the names of the potentiometers and their functions.

AD12-16(PCI)E:

Table 7.1. AD12-16(PCI)E's Potentiometers for Analog Input Circuit

VR1	Unipolar Offset Adjusting Potentiometer
VR2	Input Gain Adjusting Potentiometer
VR3	Bipolar Offset Adjusting Potentiometer

AD12-16U(PCI)E:

Table 7.2. AD12-16U(PCI)E's Potentiometers for Analog Input Circuit

VR1	Input Gain Adjusting Potentiometer for Instrument OP Amplifiers
VR2	Input Offset Adjusting Potentiometer for Instrument OP Amplifiers
VR3	Output Offset Adjusting Potentiometer for Instrument OP Amplifiers
VR4	Unipolar Offset Adjusting Potentiometer
VR8	Bipolar Offset Adjusting Potentiometer
VR9	Input Gain Adjusting Potentiometer

AD16-16(PCI)E:

Table 7.3. AD16-16(PCI)E's Potentiometers for Analog Input Circuit

VR1	Input Gain Adjusting Potentiometer for Bipolar Ranges
VR2	Input Gain Adjusting Potentiometer for Unipolar Ranges
VR3	Offset Adjusting Potentiometer for A/D Converter
VR8	Output Offset Adjusting Potentiometer for Instrument OP Amplifiers
VR9	Offset Adjusting Potentiometer for Bipolar Ranges
VR10	Input Gain Adjusting Potentiometer for Instrument OP Amplifiers
VR11	Offset Adjusting Potentiometer for Unipolar Ranges

Potentiometers for Analog Output Circuit Adjustment

The offset voltage and gain of analog output circuit have been calibrated at the factory. In case you may need to readjust the analog output circuit, the following tables show you the names of the potentiometers and their functions.

AD12-16(PCI)E:

Table 7.4. Potentiometers for Analog Output Circuits of AD12-16(PCI)E

VR4	Unipolar Offset Adjusting Potentiometer
VR5	Output Gain Adjusting Potentiometer
VR6	Bipolar Offset Adjusting Potentiometer

AD12-16U(PCI)E:

Table 7.5. Potentiometers for Analog Output Circuits of AD12-16U(PCI)E

VR5	Unipolar Offset Adjusting Potentiometer
VR6	Output Gain Adjusting Potentiometer
VR7	Bipolar Offset Adjusting Potentiometer

AD16-16(PCI)E:

Table 7.6. Potentiometers for Analog Output Circuits of AD16-16(PCI)E

VR4	Bipolar Gain Adjusting Potentiometer
VR5	Unipolar Gain Adjusting Potentiometer
VR6	Bipolar Offset Adjusting Potentiometer
VR7	Unipolar Offset Adjusting Potentiometer

8. System Reference

Specifications

1. AD12-16(PCI)E:

Table 8.1. AD12-16(PCI)E

Item	Specification
Analog Input	
Number of Channels	16 single-ended channels or 8 differential
Input Range	Un-isolated $\pm 10V$ or $0\sim 10V$
Absolute Max. Input Voltage	$\pm 20V$
Input Impedance	More than $1M\Omega$
Resolution	12 bits
Conversion Speed	$10\mu\text{sec}/\text{ch. Max.}$
Conversion Accuracy	$\pm 2\text{LSB}$ (Gain = $\times 1$ and $\times 2$)
Non-linearity error (Note 1)	$\pm 4\text{LSB}$ (Gain = $\times 4$ and $\times 8$)
Buffer Memory	256K Words FIFO or 256K Words Ring
Conversion Start Trigger	Software command, analog input signal
Conversion Stop Trigger	Software command, storage data number
Analog Output	
Number of Channel	1 single-ended channel
Output Range	Un-isolated $\pm 10V$, $\pm 5V$ or $0\sim 10V$
Output Current Ability	$\pm 5\text{mA Max.}$
Resolution	12 bits
Non-Linearity Error (Note 1)	$\pm 1/2\text{LSB}$
Conversion Speed	$6\mu\text{sec Max.}$
Power consumption (Note 2)	$+5\text{VDC}$, 1100mA Max.
Dimensions (inch)	6.9×4.2 ($176.4\text{mm} \times 107\text{mm}$)

Note 1: When the environment temperature is near 0°C or 50°C , the non-linearity error may become larger. A maximum $\pm 0.1\%$ FSR non-linearity error is possible.

We suppose you to calibrate the board under the work environment that will give you a better accuracy.

Note 2: If an external device requires this AD12-16(PCI)E board to supply $+5\text{VDC}$ from the CN1 or CN2 connectors, the power consumption of this board will be bigger than what this specification has defined.

Board Dimensions

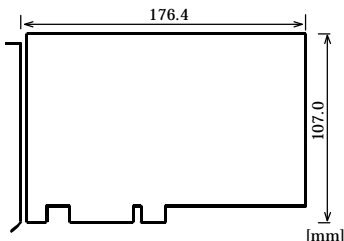

2. AD12-16U(PCI)E:

Table 8.2. AD12-16U(PCI)E

Item	Specification
Analog Input	
Number of Channels	16 single-ended channels or 8 differential
Input Range	Un-isolated $\pm 5V$, $\pm 2.5V$, 0–10V or 0–5V
Absolute Max. Input Voltage	$\pm 15V$
Input Impedance	More than 1M Ω
Resolution	12 bits
Conversion Speed	1 μ sec/ch. Max.
Conversion Accuracy Non-linearity error (<i>Note 1</i>)	$\pm 3LSB$
Buffer Memory	256K Words FIFO or 256K Words Ring
Conversion Start Trigger	Software command, analog input signal
Conversion Stop Trigger	Software command, storage data number
Analog Output	
Number of Channel	1 single-ended channel
Output Range	Un-isolated $\pm 10V$, $\pm 5V$ or 0–10V
Output Current Ability	$\pm 5mA$ Max.
Resolution	12 bits
Non-Linearity Error (<i>Note 1</i>)	$\pm 1/2LSB$
Conversion Speed	6 μ sec Max.
Power consumption (<i>Note 2</i>)	+5VDC, 1800mA Max.
Dimensions (inch)	9.0 \times 4.2 (230mm \times 107mm)

Note 1: When the environment temperature is near 0°C or 50°C, the non-linearity error may become larger. A maximum $\pm 0.1\%$ FSR non-linearity error is possible.

We suppose you to calibrate the board under the work environment that will give you a better accuracy.

Note 2: If an external device requires this AD12-16U(PCI)E board to supply +5VDC from the CN1 or CN2 connectors, the power consumption of this board will be bigger than what this specification has defined.

The power supply pins of CN1 and CN2 are fuse protected. At most 4A of current can be outputted to these power supply pins of CN1 and CN2.

Two examples of suitable fuses are:

MSF0034.4227, a SCHURTER product;

CP-4000, a NAGAZAWA DENKI's product.

Board Dimensions

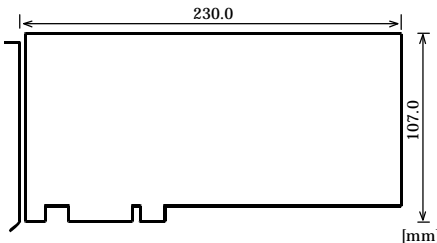

3. AD16-16(PCI)E:**Table 8.3. AD16-16(PCI)E**

Item	Specification
Analog Input	
Number of Channels	16 single-ended channels or 8 differential
Input Range	Un-isolated $\pm 10V$, $\pm 5V$, 0-10V or 0-5V
Absolute Max. Input Voltage	$\pm 20V$
Input Impedance	More than $1M\Omega$
Resolution	16 bits
Conversion Speed	10 μ sec/ch. Max.
Conversion Accuracy	$\pm 5LSB$
Non-linearity error (<i>Note 1</i>)	$\pm 5LSB$
Buffer Memory	256K Words FIFO or 256K Words Ring
Conversion Start Trigger	Software command, analog input signal
Conversion Stop Trigger	Software command, storage data number
Analog Output	
Number of Channel	1 single-ended channel
Output Range	Un-isolated $\pm 10V$ or 0-10V
Output Current Ability	$\pm 5mA$ Max.
Resolution	16 bits
Non-Linearity Error (<i>Note 1</i>)	$\pm 2LSB$
Conversion Speed	13 μ sec Max.
Power consumption (<i>Note 2</i>)	+5VDC, 1300mA Max.
Dimensions (inch)	6.9 \times 4.2 (176.4mm \times 107mm)

Note 1: When the environment temperature is near 0°C or 50°C, the non-linearity error may become larger. A maximum $\pm 0.1\%$ FSR non-linearity error is possible.

We suppose you to calibrate the board under the work environment that will give you a better accuracy.

Note 2: If an external device requires this AD16-16(PCI)E board to supply +5VDC from the CN1 or CN2 connectors, the power consumption of this board will be bigger than what this specification has defined.

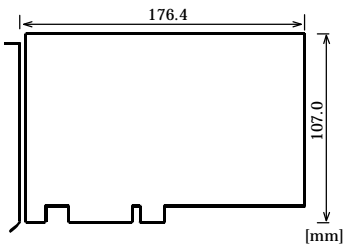
Board Dimensions

Common to All of the three boards:**Table 8.4. Common to All of the three boards**

Item	Specification
Digital I/O	
Number of Output Channels	TTL Level 4 channels (One is shared by counter output)
Number of Input Channels	TTL Level 4 Channels (Two of these are also used as counter control signals)
Counter	
Counter Device	i8254 compatible
Counter Clock	Internal 4MHz or external signal
Interrupt	
Interrupt Request Level	One of IRQ resources
Interrupt Request Causes	Up to 15 causes
Interface Connectors	
CN1	D-Type 37-Pin female connector #4-40UNC
CN2	16-Pin Pin-header connector
I/O Address	8 bits, 16 ports
Warm Up Time	15 minutes
Operation Environment	Temperature = 0-50°C Humidity : 20-90% (No-condensing)

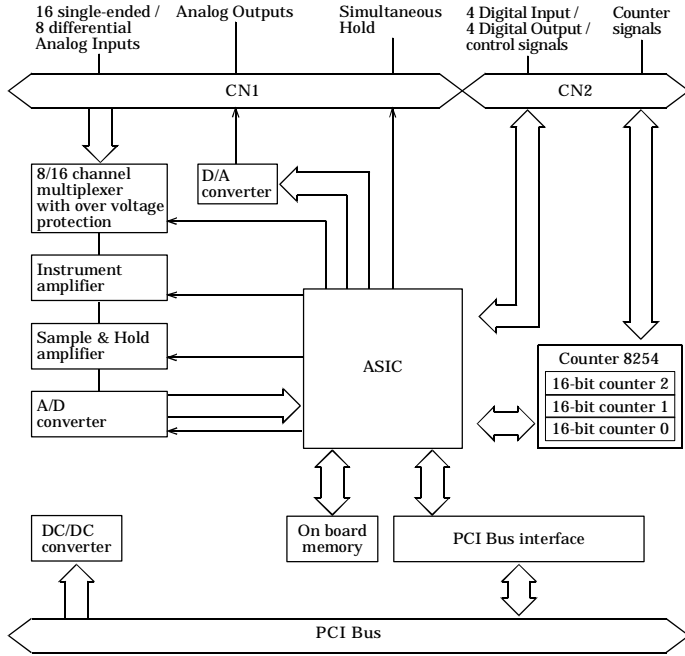

Figure 8.1. Block Diagram

Timing of External Control Signals

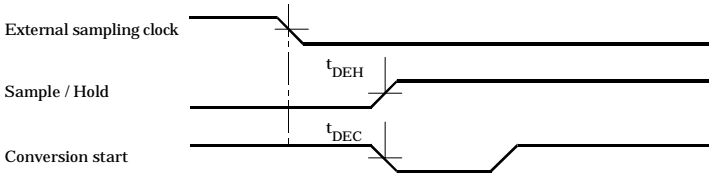

Figure 8.2. Timing Chart of External Sampling Clock

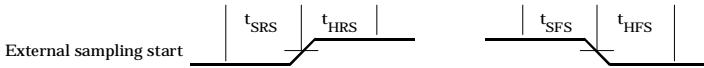

Figure 8.3. Timing Chart of External Sampling Start Trigger

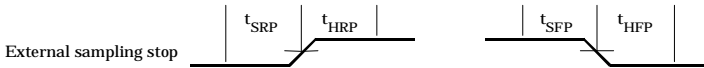

Figure 8.4. Timing Chart of External Sampling Stop Trigger

Table 8.5. Timing Table of External Control Signals

Parameter	Symbol	Typ.	Unit
Delay time from external sampling clock to first hold action	t_{DEH}	100	nsec
Delay time from external sampling clock to first A/D start pulse	t_{DEC}	100	nsec
Set up time of sampling start (Rising edge)	t_{SRS}	100	nsec
Hold time of sampling start (Rising edge)	t_{HRS}	100	nsec
Set up time of sampling start (Falling edge)	t_{SFS}	100	nsec
Hold time of sampling start (Falling edge)	t_{HFS}	100	nsec
Set up time of sampling stop (Rising edge)	t_{SRP}	100	nsec
Hold time of sampling stop (Rising edge)	t_{HRP}	100	nsec
Set up time of sampling stop (Falling edge)	t_{SFP}	100	nsec
Hold time of sampling stop (Falling edge)	t_{HFP}	100	nsec

9. Troubleshooting

If you are having trouble with your board or program, first answer the following questions to see if you can find the problem.

QUESTION	STEPS TO TAKE
Is the pilot light on?	The system must be turned on and the power source working. Check the "on" switch and the main power supply.
Did the system boot up?	If the board has been installed and the system did not boot, check the following: <ul style="list-style-type: none"> * Make sure DIP switches set correctly * Make sure the board is inserted firmly
Does your program work?	If the system booted and your program doesn't work, check the following: <ul style="list-style-type: none"> * Duplicated BIOS ROM restrictions * DIP switches have been set correctly for ROM and BIOS enable * Wrong drive was designated for this board

Note!

Before calling, make a list of the following information. Our technical representatives will need this information to help you.

1. Your name, company, and phone number
2. The brand and type of computer you are using (PC/AT)
3. OS and the version
4. Name of the CONTEC board you are using
5. Names of other boards in the computer
6. List AUTOEXEC.BAT
7. List CONFIG.SYS

10. Index

A

About the Boards, 1
About this Manual, 4
Analog Ground, 26
Analog Input, 25, 49
Analog Input Connection, 28
Analog Input Function, 33
Analog Input Settings, 10
Analog Output, 25, 50
Analog Output Connection, 31
Analog Output Function, 45
Analog Output Setting, 13
Analog Signal Connection, 25

B

Board Setup, 15

C

Checking resources, 18, 23
Converted Data Format, 43
Counter, 51
Counter Configuration, 47
Counter Function, 46

D

Demonstration Program, 49
Differential Input, 29
Digital Ground, 26, 27
Digital I/O Connection, 32
Digital Input, 27
Digital Input Function, 46
Digital Output, 26, 51
Digital Output Function, 46
Digital Signal Connection, 26

E

External Connections, 25

F

Features, 1

I

Input Channels, 34
Input Mode Selection, 44
Interrupt Function, 48
Introduction, 1

M

Memory Format, 40
Memory Operation, 40
Multichannel Mode Operation, 34

N

Number of Samplings, 37, 39
Numbers of Samplings, 38

O

Obtain Service, 3
Operation Functions, 33
Output Range Setting, 13
Over Range Detection Function, 44

P

Potentiometers for Analog Input Circuit,
54
Potentiometers for Analog Output
Circuit, 55
Product Configuration, ii

R

Repeat Times, 39
Ring, 41
RMA, 3

S

Sampling Period, 35
Set Counter and Digital I/O, 14
Set Input Mode, 10
Set Input Range, 10
Signal Connection, 28
Simultaneous Hold Output, 26
Single-ended Input, 28
Software Command, 36
Software stop Command, 38
Specifications, 57
Stop Sampling, 37

T

Timing of External Control Signals, 62
Trigger Delays, 38
Troubleshooting, 63

V

Value of Converted Data, 36, 37

W

Windows 95, 19
Windows 98, 16

A-41-755
LZC2651
010111 [971226]

CONTEC Group

- JAPAN** : Headquarters
CONTEC Co., LTD.
3-9-31, Himesato, Nishiyodogawa-ku, Osaka 555-0025, Japan
Tel : +81 (6) 6477-5219 Fax : +81 (6) 6477-1692
E-mail : intsales@osaka.contec.co.jp
- U.S.A.** : CONTEC MICROELECTRONICS U.S.A. INC.
744 South Hillview Drive, Milpitas, CA 95035 U.S.A.
Tel : +1 (408) 719-8200 Fax : +1 (408) 719-6750
E-mail : tech_support@contecusa.com
- EUROPE** : CONTEC MICROELECTRONICS EUROPE B.V.
Binnenweg 4, 2132 CT, Hoofddorp, The Netherlands
Tel : +31 (23) 567-3030 Fax : +31 (23) 567-3035
E-mail : tech_support@conteceu.nl
- KOREA** : HYOJIN CONTEC Co., LTD.
Ki-im Bldg. #399, Shindolim-Dong, Kuro-ku, Seoul, Korea
Tel : +82 (2) 2636-4277/8 Fax : +82 (2) 2636-4279
E-mail : product@conteck.com
- CHINA** : INTERNATIONAL CONTEC TECHNOLOGY CO., LTD.
B-8F, Hua Tong Building, No. B19, Che Gong Zhuang West Road,
Hai Dian District, Beijing 100044, China
Tel : +86(10)8801-8228 Fax : +86 (10)8801-8209
E-mail : ict@ict.com.cn
- SHANGHAI CONTEC MICROELECTRONICS CORP.**
No. 481 Gui Ping Road, Cao He Jing Hi-Tech Park Shanghai, 200233, China
Tel : +86 (21) 6485-1907 Fax : +86 (21) 6485-0330
E-mail : contec@contec.com.cn
- SHENYANG CONTEC MICROELECTRONICS Co., LTD.**
No. 169, Qingnian Street, Shenhe District, Shenyang 110015, China
Tel : +86 (24) 2392-9771 Fax : +86 (24) 2392-9773
- TAIWAN** : MACROMATE CORP.
8F, Universal Center, No.179, Ta-Tung Rd., Sec.1 Hsi-Chih, Taipei Hsien, Taiwan,
R.O.C
Tel : +886 (2) 2647-9353 Fax : +886 (2) 2647-9373
E-mail : intl@macromate.com.tw