

DLAP-201 Series

DLAP-201-JT2 / DLAP-201-JT2i
Edge Inference System

User's Manual



Manual Rev.: 1.0

Revision Date: January 14, 2020

Part No: 50-1Z308-1000

Revision History

Revision	Release Date	Description of Change(s)
1.0	2020-01-14	Initial Release

Preface

Copyright © 2020 ADLINK Technology, Inc.

This document contains proprietary information protected by copyright. All rights are reserved. No part of this manual may be reproduced by any mechanical, electronic, or other means in any form without prior written permission of the manufacturer.

Disclaimer

The information in this document is subject to change without prior notice in order to improve reliability, design, and function and does not represent a commitment on the part of the manufacturer.

In no event will the manufacturer be liable for direct, indirect, special, incidental, or consequential damages arising out of the use or inability to use the product or documentation, even if advised of the possibility of such damages.

Environmental Responsibility

ADLINK is committed to fulfill its social responsibility to global environmental preservation through compliance with the European Union's Restriction of Hazardous Substances (RoHS) directive and Waste Electrical and Electronic Equipment (WEEE) directive. Environmental protection is a top priority for ADLINK. We have enforced measures to ensure that our products, manufacturing processes, components, and raw materials have as little impact on the environment as possible. When products are at their end of life, our customers are encouraged to dispose of them in accordance with the product disposal and/or recovery programs prescribed by their nation or company.

Trademarks

Product names mentioned herein are used for identification purposes only and may be trademarks and/or registered trademarks of their respective companies.

Conventions

Take note of the following conventions used throughout this manual to make sure that users perform certain tasks and instructions properly.



NOTE:

Additional information, aids, and tips that help users perform tasks.



CAUTION:

Information to prevent **minor** physical injury, component damage, data loss, and/or program corruption when trying to complete a task.

Informations destinées à prévenir les blessures corporelles mineures, les dommages aux composants, la perte de données et/ou la corruption de programme lors de l'exécution d'une tâche.



WARNING:

Information to prevent **serious** physical injury, component damage, data loss, and/or program corruption when trying to complete a specific task.

Informations destinées à prévenir les blessures corporelles graves, les dommages aux composants, la perte de données et/ou la corruption de programme lors de l'exécution d'une tâche spécifique.

Table of Contents

Preface	iii
List of Tables	vii
List of Figures	ix
1 Introduction	1
1.1 Features	1
1.2 Specifications	2
1.3 Mechanical Dimensions	4
1.4 External Layout	5
1.5 Pin Definitions	7
1.5.1 Ethernet GbE Connectors	7
1.5.2 USB 3.0 Connectors	8
1.5.3 12 Volt DC Connector	9
1.5.4 CAN Bus	10
1.5.5 COM Port (Serial Port)	10
1.5.6 HDMI Connectors	11
1.5.7 USB 2.0 OTG Connector	11
1.5.8 Side I/O Slots	12
2 Getting Started	15
2.1 Unpacking Checklist	15
2.2 Cooling Considerations	15
2.3 Removing the Chassis Cover	16
2.4 Installing mSATA Module	18
2.5 Installing mPCIe 3G/4G LTE Module	19
2.6 Connecting DC Power	20
2.7 VESA Mount	21
2.8 DIN Rail Mount	22
2.9 Internal Jumper Settings	23

2.9.1	COM Mode Switches	24
2.9.2	AT Mode Switch (SWS1501)	24
2.9.3	GPIO Switch (CN1501).....	24
3	Using the System.....	25
3.1	Software Configuration	25
3.2	System Recovery.....	25
3.3	COM Port Configuration.....	26
	Important Safety Instructions.....	27
	Getting Service	29

List of Tables

Table 1-1:	Specifications	3
Table 1-2:	Front Panel I/O Connectors & Controls	5
Table 1-3:	Rear Panel I/O Connectors	6
Table 1-4:	RJ-45 GbE Pin Definition.....	7
Table 1-5:	USB 3.0 Pin Definition	8
Table 1-6:	12 Volt DC Connector Pin Definition	9
Table 1-7:	CAN Bus Pin Definition.....	10
Table 1-8:	RS-232/422/485 Connector Pin Definition.....	10
Table 1-9:	HDMI Connector Pin Definition.....	11
Table 1-10:	USB 2.0 OTG Connector Pin Information.....	11
Table 2-1:	COM Mode Switches.....	24
Table 2-2:	AT Mode Switch	24
Table 2-3:	GPIO Switch	24

This page intentionally left blank.

List of Figures

Figure 1-1:	Front View Dimensions.....	4
Figure 1-2:	Side View Dimensions.....	4
Figure 1-3:	Front Panel I/O Connectors & Controls.....	5
Figure 1-4:	Rear Panel I/O Connectors	6
Figure 1-5:	12 Volt DC Connector Mechanical Specification.....	9
Figure 1-6:	USIM / SD Side Door.....	12
Figure 2-1:	mSATA Slot.....	18
Figure 2-2:	mPCIe 3G/4G LTE Slot	19
Figure 2-3:	VESA Mount	21
Figure 2-4:	DIN Rail Mount	22
Figure 2-5:	Internal Jumpers.....	23
Figure 3-1:	Successful USB 2.0 Connection.....	26

This page intentionally left blank.

1 Introduction

ADLINK's DLAP-201 Series Edge Inference System leverages the power of NVIDIA® Jetson™ TX2/TX2i modules to deliver artificial intelligence (AI) at the edge. The DLAP-201-JT2 Edge AI Platform with integrated NVIDIA Jetson TX2 accelerates deep learning workloads for object detection, recognition, and classification. With the rapidly increased adoption of AI across industries, the DLAP-201-JT2 can be useful for a wide variety of smart city and smart manufacturing applications, including real-time traffic flow analysis at an intersection for traffic management optimization, improvement of smart bus services, strengthening of security surveillance, and many others.

The DLAP-201 Series provides a wide variety of industrial I/O and visual inferencing capabilities in a compact system. With a lockable HDMI display, two GbE ports, three USB 3.0 ports (plus a USB 2.0 OTG port for software updates), one COM port, one isolated CAN bus, one audio jack for mic-in or line-out support, 32GB of eMMC storage plus one mSATA and one SD slot for additional storage options, Wi-Fi and Bluetooth support, and an mPCIe slot and USIM socket to support other wireless communications such as LoRa and 3G/4G LTE, the DLAP-201-JT2 enables AI at the edge with exceptional performance and convenience while keeping power consumption to a minimum.

1.1 Features

- ▶ Deep learning acceleration with NVIDIA® Jetson™ TX2/TX2i
- ▶ NVIDIA® Pascal™ GPU with 256 CUDA cores
- ▶ 8GB 128-bit LPDDR4
- ▶ 32GB eMMC plus SDIO and mSATA storage interfaces
- ▶ Compact fanless system: 148(W) x 104.8(D) x 52.1(H) mm
- ▶ Wide temperature range: -20°C to 70°C

1.2 Specifications

Item	Description
System Core	
Processor	NVIDIA Jetson TX2 (TX2i optional)
Memory	8GB 128-bit LPDDR4
Storage	32GB eMMC 5.1
Graphic Output	
Graphic Output	1x HDMI 2.0 with lock (3840x2160 @60fps)
Front Panel I/O Interface	
Ethernet	2x GbE
USB 3.0	3x Type-A
Audio	1x Audio jack (mic-in or line-out)
Rear Panel I/O Interface	
USB	1x USB 2.0 OTG (Micro-USB)
Serial Port	1x COM port (DE-9 connector)
CAN Bus	1x CAN bus (2.0B)
Internal I/O Interface	
Mini PCIe	1x mPCIe slot (linked to USIM)
USIM	1x USIM slot (standard size)
Wireless (via TX2)	Wi-Fi 802.11ac (2x2 867Mb/s) Bluetooth 4.1 (24MB/s)
DIO	4 channel DIO
Debug Port	1x debug console
Storage Devices	
SATA	mSATA (full size)
SD Card	1x SDIO
Power	
DC Input	12V
AC Input	Optional 40W AC-DC adapter (ADLINK part no. 31-62156-1000-A0)
Fail Reset	Reset and recovery buttons
Buttons	Power button w/ LED indicator

Item	Description
CMOS Battery	
Type	BR2032
Protection	Reverse charge protection
Mechanical	
Antenna Holes	4x SMA
Dimensions	148(W) x 104.8(D) x 52.1(H) mm
Weight	765g
Mounting	VESA (DIN rail optional)
Environmental	
Operating Temperature	Standard -20°C to 70°C
Operating Humidity	95% @40°C (non-condensing)
Storage Temperature	-40°C to 85°C
Vibration	Operating: 5Grms, 5 to 500 Hz, 3 axes w/ mSATA
Shock	Operating: 100G, half sine 11 ms duration w/ SD, mSATA
ESD	Contact +/- 4kV, Air +/- 8kV
EMC	CE & FCC class B, (EN61000-6-4/-6-2)
Safety	IEC/CE/UL standard
RF Regulations	FCCID
Operating System Support	
Linux	Linux for Tegra (L4T)

Table 1-1: Specifications

1.3 Mechanical Dimensions

All dimensions shown in millimeters (mm).

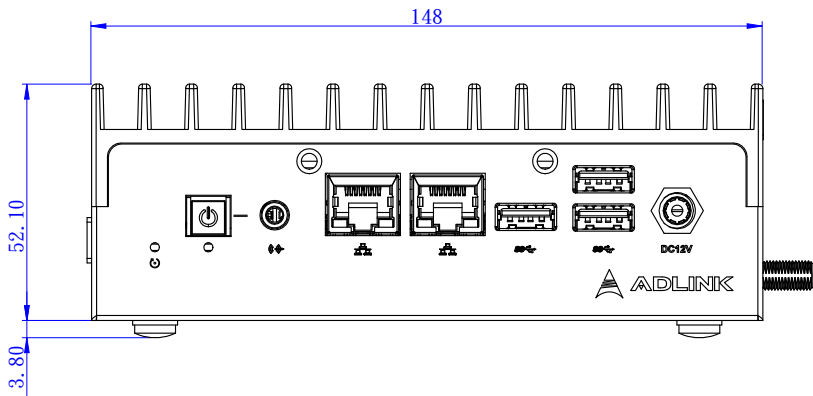

Figure 1-1: Front View Dimensions

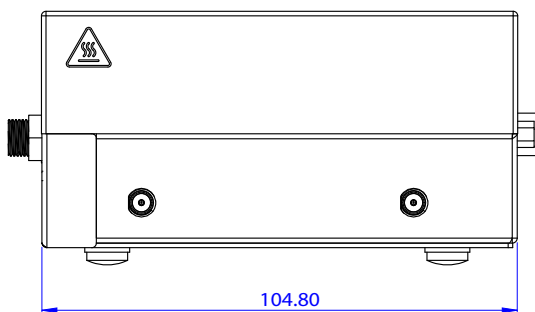

Figure 1-2: Side View Dimensions

1.4 External Layout

Front Panel

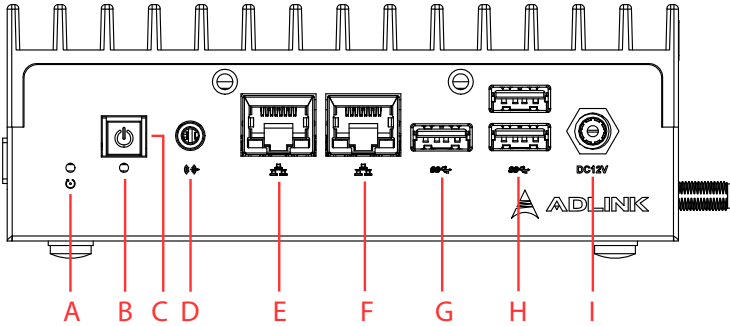

Figure 1-3: Front Panel I/O Connectors & Controls

Item	Name	Description
A	Reset button	The reset button executes a hard reset on the system.
B	Recovery button	Press this button to force the system into recovery mode. See Section 3.2 System Recovery .
C	Power button	The power button is a non-latched push button with a blue LED power indicator. If the system is powered off when the button is pressed, the system powers up and the blue LED lights up. If the system hangs, pressing and holding the button continuously for 5 seconds performs a hard shutdown on the system.
D	Audio connector	A single audio jack for mic-in or line-out.
E	GbE connector (LAN 1)	GbE from NVIDIA® Jetson™ TX2. See Section 1.5 Pin Definitions .
F	GbE connector (LAN 2)	GbE from Intel® I210. See Section 1.5 Pin Definitions .
G - H	USB 3.0 x 3	See Section 1.5.2 USB 3.0 Connectors .
I	DC connector 12V	12V DC screw-type connector. See Section 1.5.3 12 Volt DC Connector .

Table 1-2: Front Panel I/O Connectors & Controls

Rear Panel

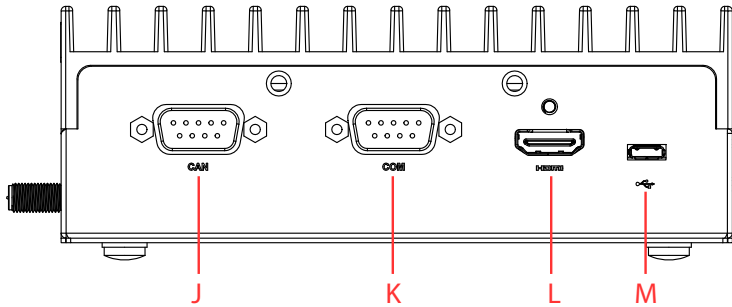

Figure 1-4: Rear Panel I/O Connectors

Item	Name	Description
J	CAN bus	CAN 2.0B (backward compatible with 2.0A)
K	Serial port	COM port (DE-9 connector); RS-232/422/485 supported by jumper selection
L	HDMI port	HDMI 2.0 with lock
M	USB 2.0	USB 2.0 OTG (Micro-USB)

Table 1-3: Rear Panel I/O Connectors

1.5 Pin Definitions

1.5.1 Ethernet GbE Connectors

The DLAP-201 series comes with two RJ-45 connectors:

- ▶ NVIDIA® Jetson™ TX2 (LAN 1)
- ▶ Intel® I210 (LAN 2)

LAN LED connection speed color indicators:

- ▶ Yellow (left LED): 1Gbps
- ▶ Green (right LED): 100Mbps

The following table provides details for the RJ-45 GbE pin connections.

Pin #	10BASE-T/ 100BASE-TX	1000BASE-T
1	TX+	LAN_TX0+
2	TX-	LAN_TX0-
3	RX+	LAN_TX1+
4	—	LAN_TX2+
5	—	LAN_TX2-
6	RX-	LAN_TX1-
7	—	LAN_TX3+
8	—	LAN_TX3-

Table 1-4: RJ-45 GbE Pin Definition

1.5.2 USB 3.0 Connectors

The USB 3.0 ports support a USB Type-A connection, compatible with SuperSpeed, Hi-Speed, full-speed, and low-speed USB devices. It is suitable for USB peripherals including USB cameras.

The following table provides details for the USB pin connections.

Pin #	Signal Name
1	USB3.0_P5VA
2	USB2_CMAN
3	USB2_CMAP
4	GND
5	USB3A_CMRXN
6	USB3A_CMRXP
7	GND
8	USB3A_CMTXN
9	USB3A_CMTXP

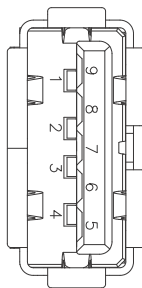

Table 1-5: USB 3.0 Pin Definition

1.5.3 12 Volt DC Connector

The system requires a DC power source with a screw-type connector.

Pin	Signal
1	+12V
2	GND
3	GND

Table 1-6: 12 Volt DC Connector Pin Definition

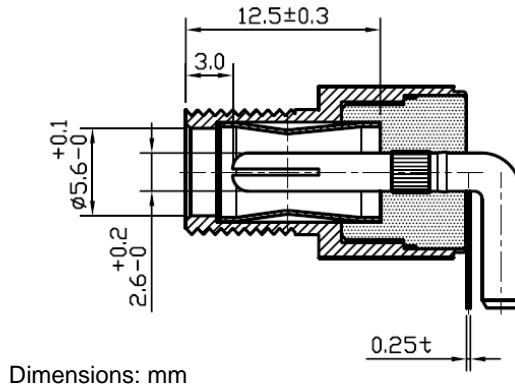

Figure 1-5: 12 Volt DC Connector Mechanical Specification

1.5.4 CAN Bus

The Controller Area Network (CAN) enables communication among devices. The table below provides CAN bus pin information.

Pin	Signal	Description
1	NC	(Not connected)
2	CAN0_Low	Differential CAN signal negative level
3	CAN0_GND	CAN interface ground
4	NC	(Not connected)
5	NC	(Not connected)
6	NC	(Not connected)
7	CAN0_High	Differential CAN signal positive level
8	NC	(Not connected)
9	NC	(Not connected)

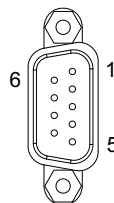

Table 1-7: CAN Bus Pin Definition

1.5.5 COM Port (Serial Port)

RS-232/422/485 are supported by jumper selection. For details, see **Section 2.9.1 COM Mode Switches** on page 24.

Pin	RS-232	RS-422	RS-485
1	NC (not connected)	COM_TXD_N	COM_D-
2	COM_RXD	COM_TXD_P	COM_D+
3	COM_TXD	COM_RXD_P	NC
4	NC	COM_RXD_N	NC
5	COM_GND	NC	NC
6	NC	NC	NC
7	COM_RTS#	NC	NC
8	COM_RCTS#	NC	NC
9	NC	NC	NC

Table 1-8: RS-232/422/485 Connector Pin Definition

1.5.6 HDMI Connectors

The rear panel supports HDMI 2.0.

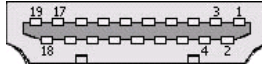

Pin #	Signal	Pin #	Signal
1	TMDS Data2+	2	TMDS Data2 Shield
3	TMDS Data2–	4	TMDS Data1+
5	TMDS Data1 Shield	6	TMDS Data1–
7	TMDS Data0+	8	TMDS Data0 Shield
9	TMDS Data0–	10	TMDS Clock+
11	TMDS Clock Shield	12	TMDS Clock–
13	CEC	14	Reserved
15	SCL	16	SDA
17	DDC/CEC Ground	18	+5 V Power
19	Hot Plug Detect		

Table 1-9: HDMI Connector Pin Definition

1.5.7 USB 2.0 OTG Connector

The DLAP-201 supports a USB 2.0 OTG Micro-USB Type-B connection for system recovery. The pin definition is as follows.

Pin	Signal	Description
1	VCC_USBDev	USB device power
2	USB_D1_n	Universal Serial Bus Port 1 / USB-Client differential pair
3	USB_D1_p	
4	USB_ID	USB ID pin
5	GND_USBDev	USB GND

Table 1-10: USB 2.0 OTG Connector Pin Information

1.5.8 Side I/O Slots

The I/O connectors accessible from the right side panel of the DLAP-201 are described below.

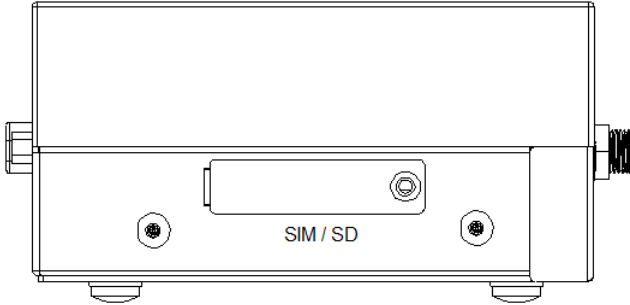

Figure 1-6: USIM / SD Side Door

SD Card Slot

For additional storage, use the side door to install or remove a user-provided SD card.

USIM Slot

The DLAP-201 is equipped with a USIM slot connected to the mPCIe connector for use with a user-provided SIM card and 3G/4G mPCIe module to provide cellular communication. Install or remove a SIM card module via the side door.



The 3G/4G mPCIe module requires a user-provided SIM card for communication via a telecom operator. See Section 2.5 Installing mPCIe 3G/4G LTE Module on page 19.

Orientation

Insert the SIM and SD cards with the orientations shown below.



This page intentionally left blank.

2 Getting Started

2.1 Unpacking Checklist

Before unpacking, check the shipping carton for any damage. If the shipping carton and/or contents are damaged, inform your dealer immediately. Retain the shipping carton and packing materials for inspection. Obtain authorization from your dealer before returning any product to ADLINK. Ensure that the following items are included in the package.

- ▶ DLAP-201 unit
- ▶ Wi-Fi antennas
- ▶ Screw pack
- ▶ VESA mount kit (plus optional DIN rail kit if applicable)

2.2 Cooling Considerations

All heat-generating components of the DLAP-201 are located on the left side of the system. These components directly contact the heat sink via thermal pads to dissipate heat. To maximize efficiency of heat dissipation, maintain a minimum of 2 inches (5cm) clearance on the top of the DLAP-201.

2.3 Removing the Chassis Cover

To access the DLAP-201's internals, remove the underside of the chassis as follows.

1. On the front panel, remove the nut and washer from the DC12V connector and remove the two mounting screws, all indicated by red circles in the figure below.



2. On the underside of the device, remove the screw indicated by the red circle.



- Slide the cover in the direction indicated by the red arrow to the position shown below.

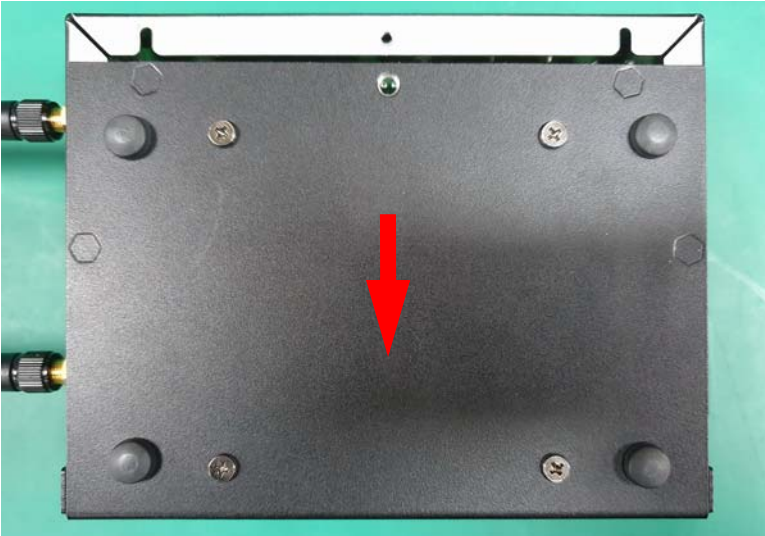

- Lift the cover off of the chassis.



Reverse the steps above to replace the bottom cover.

2.4 Installing mSATA Module

Use the following steps to install an mSATA module.

1. Insert the mSATA module into the indicated slot (under the wires) at an angle.

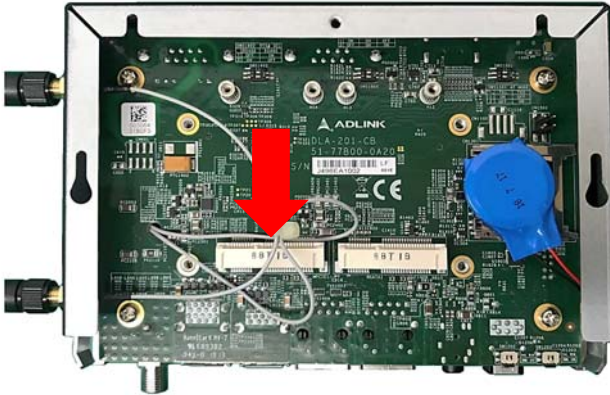

Figure 2-1: mSATA Slot

2. Press down on the mSATA module until it is seated, then secure it with two M2.5-P-head-L5 screws (not provided).
3. Replace the bottom cover of the chassis.



Take care not to remove or damage any wires while installing the module.

2.5 Installing mPCIe 3G/4G LTE Module

Use the following steps to install an mPCIe 3G/4G LTE module.



NOTE:

Use of the mPCIe 3G/4G LTE module requires installation of a SIM card. See Section 1.5.8 Side I/O Slots on page 12.

1. Insert the mPCIe 3G/4G LTE module into the indicated slot at an angle.

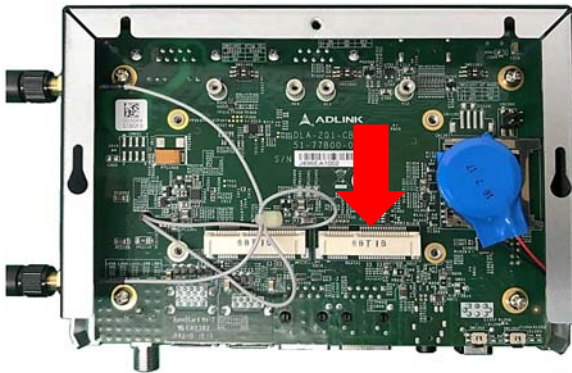

Figure 2-2: mPCIe 3G/4G LTE Slot

2. Press down on the module until it is seated, then secure it to the board using two M2.5-P-head-L5 screws (not provided).
3. Attach the wires and antennas that came with your 3G/4G LTE kit.
4. Replace the bottom cover of the chassis.

2.6 Connecting DC Power



Before providing DC power to the DLAP-201, ensure the voltage and polarity provided are compatible with the DC input. Improper input voltage and/or polarity can be responsible for system damage.

Avant de connecter le PC DLAP-201 à une source de courant continu, veuillez vous assurer de la polarité de la tension conformément à l'entrée CC du PC. Une tension et/ou une polarité incorrectes peuvent causer des dommages irréversibles sur le système.

DC power sources must comply with LPS and SELV circuits with no energy hazard, as well as the following:

- ▶ IEC 62368-1 + IEC 60950-1 + UL 62368-1
- ▶ Output voltage: 12 VDC
- ▶ Output current: 2.7A minimum
- ▶ TMA: 50°C minimum

The DLAP-201 DC power input connector uses V+, V-, and chassis ground pins and accepts input voltage as shown previously.

Customers may optionally order a DC power adapter from ADLINK: DC plug with lock (part no. 31-62156-1000-A0).

2.7 VESA Mount

The DLAP-201 controller ships with a VESA 100 mounting bracket and four M4 screws. Follow the steps below to mount the device.

1. Attach the VESA bracket to the wall (or other suitable mounting surface) such that its keyhole-shaped mounting holes are oriented with the wider openings at the top.
2. Secure the four M4 screws to the bottom of the chassis.
3. Securely attach the device to the VESA bracket by first inserting the heads of the screws into the wider openings of the VESA bracket's mounting holes, then sliding the device down such that the screws are now firmly held by the narrower portions of the mounting holes.

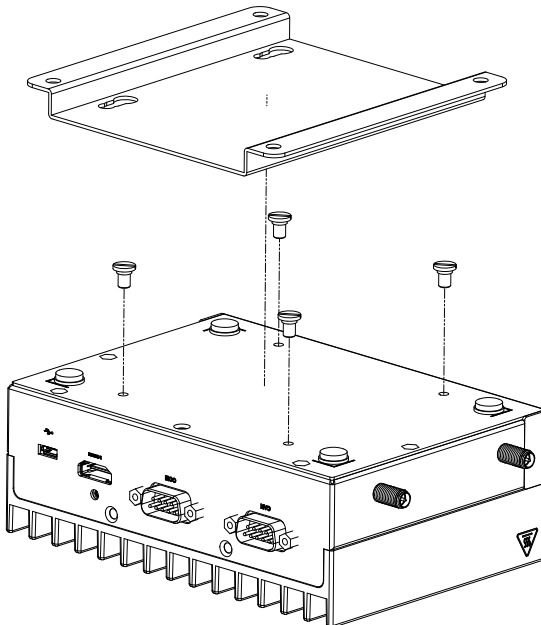

Figure 2-3: VESA Mount

2.8 DIN Rail Mount

The DLAP-201 controller may optionally include a DIN rail mount kit, with its own six M4 screws, in addition to the standard VESA mount kit. Follow these steps to install the DIN rail bracket.

1. Use two M4 screws (pointing upwards in the red box below) to attach the DIN rail bracket to the adapter plate.
2. Use four M4 screws (circled in red below) to attach the DIN rail bracket assembly to the DLAP-201 chassis.

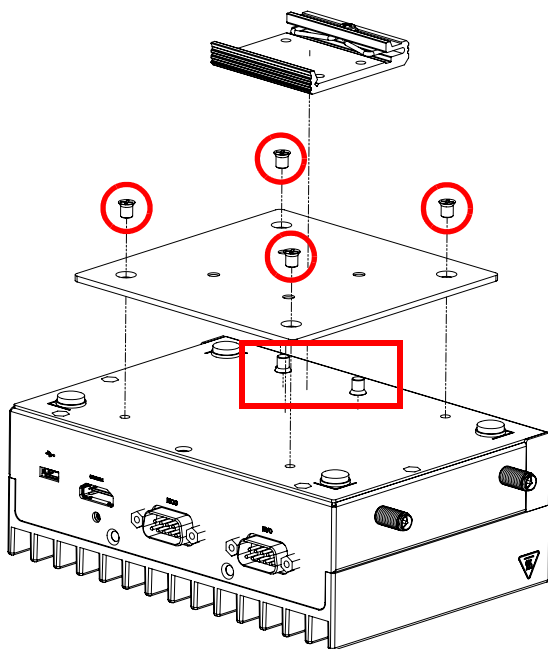

Figure 2-4: DIN Rail Mount

2.9 Internal Jumper Settings

The interior of the DLAP-201 controller features four jumper switches as shown in the figure.

- ▶ COM Mode Switches: SWS1601, SWS1602
- ▶ AT Mode Switch: SWS1501
- ▶ GPIO Switch: CN1501

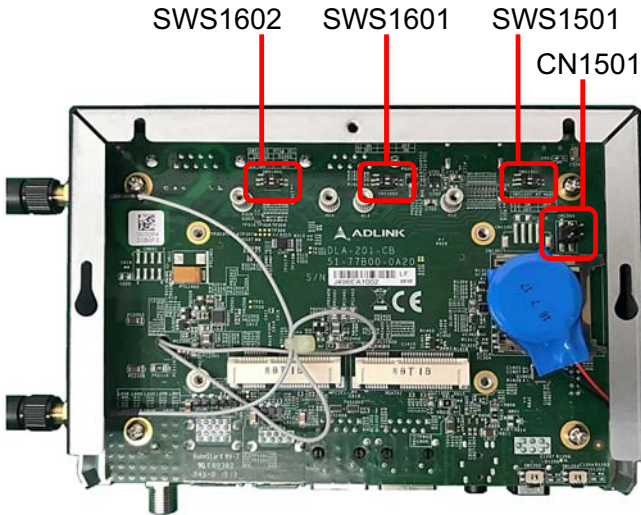

Figure 2-5: Internal Jumpers

Detailed information for each switch appears in the sections below.

2.9.1 COM Mode Switches

The COM port's communication protocol is determined by two jumper switches: SWS1601 and SWS1602. By default they are configured for RS-232 but may be changed to RS-422 or RS-485 by setting their pins as indicated in the table below.

Switch	Pin	RS-232 (default)	RS-422	RS-485
SWS1601	1	ON	ON	OFF
	2	OFF	ON	ON
SWS1602	1	-	OFF	ON
	2	-	ON	OFF

Table 2-1: COM Mode Switches

For instructions about setting the port's direction (TX/RX), see **Section 3.3 COM Port Configuration** on page 26.

2.9.2 AT Mode Switch (SWS1501)

The AT mode may be modified via SWS1501 as follows.

Pin	Default	TX1	TX2
1	OFF	ON	OFF
2	OFF	OFF	ON

Table 2-2: AT Mode Switch

2.9.3 GPIO Switch (CN1501)

The table below provides GPIO CN1501 switch pin information.

Pin	Setting
1	GPIO_0
2	GPIO_1
3	GPIO_2
4	GPIO_3

Table 2-3: GPIO Switch

3 Using the System

3.1 Software Configuration

The DLAP-201 ships with a customized NVIDIA Linux for Tegra (L4T) image pre-installed. The latest version of this custom L4T image and other relevant files are available on our website:

https://www.adlinktech.com/Products/Deep_Learning_Accelerator_Platform_and_Server/Inference_Platform/DLAP-201-JT2

For a non-customized version, download the TX2's "L4T Driver Package" directly from NVIDIA:

<https://developer.nvidia.com/embedded/linux-tegra>

3.2 System Recovery

You will need a Linux host PC (Ubuntu is recommended) in order to flash your client device with a new system image. Complete the following steps on the client before performing the host PC steps.

Client (DLAP-201-JT2):

1. Connect the OTG cable to the USB 2.0 port.
2. Press the reset and recovery buttons at the same time.
3. Press the power switch.
4. Release the reset button.
5. Release the recovery button.

Host PC:

1. Ensure python2.7 and python-minimal (or equivalent packages) are installed on the host PC.
2. Connect the host PC to the client via OTG cable.
3. Open a terminal on the host PC and run this command:

```
# lsusb
```

4. Look for “Nvidia Corp.” in the output (an example is circled in red in the screenshot below). If found, the host PC recognizes the client and you may proceed. If not, double-check the OTG cable connection and perform troubleshooting as needed until the client is recognized.

```
File Edit View Search Terminal Help
adlink@adlink:~$ lsusb
Bus 002 Device 001: ID 1d6b:0003 Linux Foundation 3.0 root hub
Bus 001 Device 015: ID 046e:6000 Behavior Tech. Computer Corp.
Bus 001 Device 016: ID 045e:00cb Microsoft Corp. Basic Optical Mouse v2.0
Bus 001 Device 024: ID 0955:7f21 Nvidia Corp.
Bus 001 Device 001: ID 1d6b:0002 Linux Foundation 2.0 root hub
adlink@adlink:~$
```

Figure 3-1: Successful USB 2.0 Connection

5. Now run the following commands in the directory that contains your downloaded L4T file:

```
# sudo tar xzvf Linux_for_Tegra.tar.gz
# cd Linux_for_Tegra
# sudo ./flash.sh jetson-tx2 mmcblk0p1
```

6. Allow the update to complete. For details about available command-line options, read the “flash.sh” file.

3.3 COM Port Configuration

By default, the DLAP-201 is configured to support the RS-232 protocol. For details about changing to RS-422/485, see **Section 2.9 Internal Jumper Settings** on page 23.

To set the direction to transmit (TX) or receive (RX), open a terminal within DLAP-201’s Linux system and run these commands:

```
# sudo -s
# cd /sys/class/gpio
# echo 244 > export
# echo out > gpio244/direction
```

To set the direction to TX, run this command:

```
# echo 1 > gpio244/value
```

Otherwise, to set the direction to RX, run this command:

```
# echo 0 > gpio244/value
```

Important Safety Instructions

For user safety, please read and follow all instructions, Warnings, Cautions, and Notes marked in this manual and on the associated device before handling/operating the device, to avoid injury or damage.

S'il vous plaît prêter attention stricte à tous les avertissements et mises en garde figurant sur l'appareil , pour éviter des blessures ou des dommages.

- ▶ Read these safety instructions carefully.
- ▶ Keep the User's Manual for future reference.
- ▶ Read the Specifications section of this manual for detailed information on the recommended operating environment.
- ▶ The device can be operated at an ambient temperature of 55°C.
- ▶ When installing/mounting or uninstalling/removing device, or when removal of a chassis cover is required for user servicing:
 - ▷ Turn off power and unplug any power cords/cables.
 - ▷ Reinstall all chassis covers before restoring power.
- ▶ To avoid electrical shock and/or damage to device:
 - ▷ Keep device away from water or liquid sources.
 - ▷ Keep device away from high heat or humidity.
 - ▷ Keep device properly ventilated (do not block or cover ventilation openings).
 - ▷ Always use recommended voltage and power source settings.
 - ▷ Always install and operate device near an easily accessible electrical outlet.
 - ▷ Secure the power cord (do not place any object on/over the power cord).
 - ▷ Only install/attach and operate device on stable surfaces and/or recommended mountings.
- ▶ If the device will not be used for long periods of time, turn off and unplug it from its power source
- ▶ Never attempt to repair the device, which should only be serviced by qualified technical personnel using suitable tools

- ▶ A Lithium-type battery may be provided for uninterrupted backup or emergency power.



CAUTION:

Risk of explosion if battery is replaced with one of an incorrect type; please dispose of used batteries appropriately.

Risque d'explosion si la pile est remplacée par une autre de type incorrect. Veuillez jeter les piles usagées de façon appropriée.

- ▶ The device must be serviced by authorized technicians when:
 - ▷ The power cord or plug is damaged.
 - ▷ Liquid has entered the device interior.
 - ▷ The device has been exposed to high humidity and/or moisture.
 - ▷ The device is not functioning or does not function according to the User's Manual.
 - ▷ The device has been dropped and/or damaged and/or shows obvious signs of breakage.
- ▶ Disconnect the power supply cord before loosening the thumbscrews and always fasten the thumbscrews with a screwdriver before starting the system up.
- ▶ It is recommended that the device be installed only in a server room or computer room where access is:
 - ▷ Restricted to qualified service personnel or users familiar with restrictions applied to the location, reasons therefor, and any precautions required.
 - ▷ Only afforded by the use of a tool or lock and key, or other means of security, and controlled by the authority responsible for the location.

	<p>BURN HAZARD</p> <p>Touching this surface could result in bodily injury. To reduce risk, allow the surface to cool before touching.</p> <p>RISQUE DE BRÛLURES</p> <p><i>Ne touchez pas cette surface, cela pourrait entraîner des blessures.</i></p> <p><i>Pour éviter tout danger, laissez la surface refroidir avant de la toucher.</i></p>
---	---

Getting Service

Ask an Expert: <http://askanexpert.adlinktech.com>

ADLINK Technology, Inc.

9F, No.166 Jian Yi Road, Zhonghe District
New Taipei City 235, Taiwan
Tel: +886-2-8226-5877
Fax: +886-2-8226-5717
Email: service@adlinktech.com

Ampro ADLINK Technology, Inc.

5215 Hellyer Avenue, #110
San Jose, CA 95138, USA
Tel: +1-408-360-0200
Toll Free: +1-800-966-5200 (USA only)
Fax: +1-408-360-0222
Email: info@adlinktech.com

ADLINK Technology (China) Co., Ltd.

300 Fang Chun Rd., Zhangjiang Hi-Tech Park
Pudong New Area, Shanghai, 201203 China
Tel: +86-21-5132-8988
Fax: +86-21-5132-3588
Email: market@adlinktech.com

ADLINK Technology GmbH

Hans-Thoma-Strasse 11
D-68163 Mannheim, Germany
Tel: +49-621-43214-0
Fax: +49-621 43214-30
Email: emea@adlinktech.com

Please visit the Contact page at www.adlinktech.com for information on how to contact the ADLINK regional office nearest you.